



Department of Electrical Engineering
Indian Institute of Technology, Delhi
Hauz Khas, New Delhi 110016

NIQ no. IITD/EE/PLN03-BEEN/IEC/2012/1

Due Date: 21.5.2012, 5 PM

**Notice inviting quotations for
a seven contact probe for RF and DC signals**

Sealed quotations are invited for a seven contact probe for RF and DC signals. The required specifications are given below. The purchase will be made through a two part bidding process. Technical and Financial bids have to be made separately. Complete technical information should be provided along with the Technical bid. Please refer to the last page on Terms and Conditions for details on how and when to submit Technical and Financial bids.

Required Specifications for the seven contact probe

1. There should be seven contacts, in the configuration as shown in the figure below. P is a power signal, L is a logic (DC to 500 MHz) signal, G is ground, and S is a RF (8 GHz) signal.

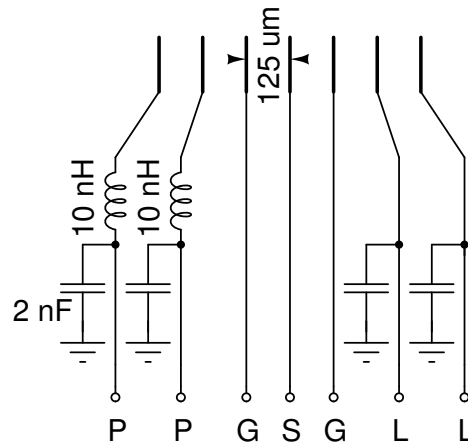

2. Each power (P) signal should have an inductance of 10 nH and capacitance to ground of about 2 nF .
3. The pitch between adjacent probes should be 125 μm .
4. Contact area of the probe should not be more than 12 μm X 12 μm .
5. Power pin should support at-least 400 mA of DC current.
6. Maximum insertion loss of RF signal is 3 dB.

7. Minimum return loss of RF signal is 12 dB.
8. The probe tips should be made of tungsten.
9. Other end of power and logic pins should have BNC female connector.
10. Other end of signal pin should have an SMA female connector.

Dr. S. Chatterjee
(Chairman, purchase committee)

Terms and Conditions

1. Please submit the TECHNICAL and FINANCIAL bids in separate sealed envelopes. Mark the two envelopes clearly as “Technical Bid” and “Financial Bid” respectively. Both the sealed envelopes should be sent in a single sealed envelope, clearly marked as “Quotation for a seven contact probe for RF and DC signals”. The quote should reach the following address on or before **21.5.2012, 5 PM**.

Dr. S. Chatterjee
VLSI Design Tools and Technology
Block IV, Room 202
IIT Delhi, Hauz Khas
New Delhi, 110016
2. Please quote prices for FOB New Delhi, inclusive of all taxes and duties.
3. Quote should be in Indian Rupees for agents of Indian manufacturers, or in foreign currency, for agents of foreign manufacturers, and needs to be valid for at least three months.
4. Attach all the technical literature and a list of similar installations done in India.
5. If the quote is being submitted by a representative of the manufacturer, a valid agency-ship or dealership certificate authorizing the agent to quote to IIT Delhi on behalf of the manufacturers should be enclosed.
6. Complete set of manuals for the operation of the equipment should be given.
7. Clearly specify the installation requirements - such as space, power, frequency, environment etc.
8. If the item quoted is proprietary in nature, please enclose proprietary certificate from the principals stating, “Certified that _____ is a proprietary item of M/s _____ and no other manufacturer makes this item.”
9. Please attach a signed and stamped compliance chart for the specifications. The format of the compliance chart is attached to this document.
10. Please specify all of your terms and conditions clearly, including delivery period.
11. Mode of payment for purchases in foreign currency are through irrevocable letter of credit, or through wire transfer on delivery. Only bank charges within India are payable by IIT Delhi, all bank charges outside India are the responsibility of the seller. For purchases in INR, payment is on delivery.
12. The Institute reserves the right to accept or reject any or all quotations without assigning any reasons thereof.

Dr. S. Chatterjee
(Chairman, purchase committee)