

Notice Inviting Quotation (E-Procurement mode)

INDIAN INSTITUTE OF TECHNOLOGY DELHI

HAUZ KHAS, NEW DELHI-110016

Dated: 08/09/2017

Open Tender Notice No. IITD/BMCH(SP-1234)/2017

Indian Institute of Technology Delhi is in the process of purchasing following item(s) as per details as given as under.

| | |
|--|--|
| Details of the item | Test rig for wheel-axle bearing health monitoring |
| Earnest Money Deposit to be submitted | Nil |
| Warranty | Minimum 2 year |
| Performance security | Nil |

Tender Documents may be downloaded from Central Public Procurement Portal <http://eprocure.gov.in/eprocure/app>. Aspiring Bidders who have not enrolled / registered in e-procurement should enroll / register before participating through the website <http://eprocure.gov.in/eprocure/app>. The portal enrolment is free of cost. Bidders are advised to go through instructions provided at 'Instructions for online Bid Submission'.

Tenderers can access tender documents on the website (For searching in the NIC site, kindly go to Tender Search option and type 'IIT'. Thereafter, Click on "GO" button to view all IIT Delhi tenders). Select the appropriate tender and fill them with all relevant information and submit the completed tender document online on the website <http://eprocure.gov.in/eprocure/app> as per the schedule given in the next page.

No manual bids will be accepted. All quotation (both Technical and Financial should be submitted in the E-procurement portal).

Schedule

| | |
|--|---|
| Name of Organization | Indian Institute of Technology Delhi |
| Tender Type (Open/Limited/EOI/Auction/Single) | Open |
| Tender Category (Services/Goods/works) | Goods |
| Type/Form of Contract (Work/Supply/ Auction/ Service/ Buy/ Empanelment/ Sell) | Buy |
| Product Category (Civil Works/Electrical Works/Fleet Management/ Computer Systems) | Other (Electronic instrument) |
| Source of Fund (Institute/Project) | Project Code: PLN03/BMCH |
| Is Multi Currency Allowed | Yes |
| Date of Issue/Publishing | 08/09/2017 (17:30 Hrs) |
| Document Download/Sale Start Date | 08/09/2017 (17:30 Hrs) |
| Document Download/Sale End Date | 29/09/2017(15:00 Hrs) |
| Date for Pre-Bid Conference | N/A |
| Venue of Pre-Bid Conference | --- |
| Last Date and Time for Uploading of Bids | 29/09/2017(15:00 Hrs) |
| Date and Time of Opening of Technical Bids | 03/10/2017(15:00 Hrs) |
| Tender Fee | Rs. Nil__/- (For Tender Fee) |
| EMD | Rs. Nil__/- (For EMD) (To be paid through RTGS/NEFT. IIT Delhi Bank details are as under: Name of the Bank A/C : IITD Revenue Account SBI A/C No. : 10773572622 Name of the Bank : State Bank of India, IIT Delhi, Hauz Khas, New Delhi-110016 IFSC Code : SBIN0001077 MICR Code : 110002156 Swift No. : SBININBB547 (This is mandatory that UTR Number is provided in the on-line quotation/bid. (Kindly refer to the UTR Column of the Declaration Sheet at Annexure-II) |
| No. of Covers (1/2/3/4) | 02 |
| Bid Validity days (180/120/90/60/30) | 60 days (From last date of opening of tender) |
| Address for Communication | Dr. Ashish K Darpe Mechanical Engg. Deptt., Indian Institute of Technology Delhi Hauz Khas, New Delhi-110016 |
| Contact No. | 011-2659-6095 |
| Email Address | akdarpe@mech.iitd.ac.in |

**Chairman Purchase Committee
(Buyer Member)**

Instructions for Online Bid Submission:

As per the directives of Department of Expenditure, this tender document has been published on the Central Public Procurement Portal ([URL:http://eprocure.gov.in/eprocure/app](http://eprocure.gov.in/eprocure/app)). The bidders are required to submit soft copies of their bids electronically on the CPP Portal, using valid Digital Signature Certificates. The instructions given below are meant to assist the bidders in registering on the CPP Portal, prepare their bids in accordance with the requirements and submitting their bids online on the CPP Portal.

More information useful for submitting online bids on the CPP Portal may be obtained at:

<http://eprocure.gov.in/eprocure/app>

REGISTRATION

- 1) Bidders are required to enroll on the e-Procurement module of the Central Public Procurement Portal ([URL:http://eprocure.gov.in/eprocure/app](http://eprocure.gov.in/eprocure/app)) by clicking on the link “Click here to Enroll”. Enrolment on the CPP Portal is free of charge.
- 2) As part of the enrolment process, the bidders will be required to choose a unique username and assign a password for their accounts.
- 3) Bidders are advised to register their valid email address and mobile numbers as part of the registration process. These would be used for any communication from the CPP Portal.
- 4) Upon enrolment, the bidders will be required to register their valid Digital Signature Certificate (Class II or Class III Certificates with signing key usage) issued by any Certifying Authority recognized by CCA India (e.g. Sify / TCS / nCode / eMudhra etc.), with their profile.
- 5) Only one valid DSC should be registered by a bidder. Please note that the bidders are responsible to ensure that they do not lend their DSCs to others which may lead to misuse.
- 6) Bidder then logs in to the site through the secured log-in by entering their user ID / password and the password of the DSC / eToken.

SEARCHING FOR TENDER DOCUMENTS

- 1) There are various search options built in the CPP Portal, to facilitate bidders to search active tenders by several parameters. These parameters could include Tender ID, organization name, location, date, value, etc. There is also an option of advanced search for tenders, wherein the bidders may combine a number of search parameters such as organization name, form of contract, location, date, other keywords etc. to search for a tender published on the CPP Portal.
- 2) Once the bidders have selected the tenders they are interested in, they may download the required documents / tender schedules. These tenders can be moved to the respective ‘My Tenders’ folder. This would enable the CPP Portal to intimate the bidders through SMS / e-mail in case there is any corrigendum issued to the tender document.
- 3) The bidder should make a note of the unique Tender ID assigned to each tender, in case they want to obtain any clarification / help from the Helpdesk.

PREPARATION OF BIDS

- 1) Bidder should take into account any corrigendum published on the tender document before submitting their bids.
- 2) Please go through the tender advertisement and the tender document carefully to understand the documents required to be submitted as part of the bid. Please note the number of covers in which the bid documents have to be submitted, the number of documents - including the names and content of

each of the document that need to be submitted. Any deviations from these may lead to rejection of the bid.

- 3) Bidder, in advance, should get ready the bid documents to be submitted as indicated in the tender document / schedule and generally, they can be in PDF / XLS / RAR / DWF formats. Bid documents may be scanned with 100 dpi with black and white option.
- 4) To avoid the time and effort required in uploading the same set of standard documents which are required to be submitted as a part of every bid, a provision of uploading such standard documents (e.g. PAN card copy, annual reports, auditor certificates etc.) has been provided to the bidders. Bidders can use “My Space” area available to them to upload such documents. These documents may be directly submitted from the “My Space” area while submitting a bid, and need not be uploaded again and again. This will lead to a reduction in the time required for bid submission process.

SUBMISSION OF BIDS

- 1) Bidder should log into the site well in advance for bid submission so that he/she upload the bid in time i.e. on or before the bid submission time. Bidder will be responsible for any delay due to other issues.
- 2) The bidder has to digitally sign and upload the required bid documents one by one as indicated in the tender document.
- 3) Bidder has to select the payment option as “on-line” to pay the tender fee / EMD as applicable and enter details of the instrument. Whenever, EMD / Tender fees is sought, bidders need to pay the tender fee and EMD separately on-line through RTGS (Refer to Schedule, Page No.2).
- 4) A standard BoQ format has been provided with the tender document to be filled by all the bidders. Bidders are requested to note that they should necessarily submit their financial bids in the format provided and no other format is acceptable. Bidders are required to download the BoQ file, open it and complete the white colored (unprotected) cells with their respective financial quotes and other details (such as name of the bidder). No other cells should be changed. Once the details have been completed, the bidder should save it and submit it online, without changing the filename. If the BoQ file is found to be modified by the bidder, the bid will be rejected.

OR

In some cases Financial Bids can be submitted in PDF format as well (in lieu of BOQ).

- 5) The server time (which is displayed on the bidders’ dashboard) will be considered as the standard time for referencing the deadlines for submission of the bids by the bidders, opening of bids etc. The bidders should follow this time during bid submission.
- 6) All the documents being submitted by the bidders would be encrypted using PKI encryption techniques to ensure the secrecy of the data. The data entered cannot be viewed by unauthorized persons until the time of bid opening. The confidentiality of the bids is maintained using the secured Socket Layer 128 bit encryption technology. Data storage encryption of sensitive fields is done.
- 7) The uploaded tender documents become readable only after the tender opening by the authorized bid openers.
- 8) Upon the successful and timely submission of bids, the portal will give a successful bid submission message & a bid summary will be displayed with the bid no. and the date & time of submission of the bid with all other relevant details.
- 9) Kindly add scanned PDF of all relevant documents in a single PDF file of compliance sheet.

ASSISTANCE TO BIDDERS

- 1) Any queries relating to the tender document and the terms and conditions contained therein should be addressed to the Tender Inviting Authority for a tender or the relevant contact person indicated in the tender.
- 2) Any queries relating to the process of online bid submission or queries relating to CPP Portal in general may be directed to the 24x7 CPP Portal Helpdesk. The contact number for the helpdesk is 1800 233 7315.

General Instructions to the Bidders

- 1) The tenders will be received online through portal <http://eprocure.gov.in/eprocure/app> . In the Technical Bids, the bidders are required to upload all the documents in .pdf format.
- 2) Possession of a Valid Class II/III Digital Signature Certificate (DSC) in the form of smart card/e-token in the company's name is a prerequisite for registration and participating in the bid submission activities through <https://eprocure.gov.in/eprocure/app>. Digital Signature Certificates can be obtained from the authorized certifying agencies, details of which are available in the web site <https://eprocure.gov.in/eprocure/app> under the link “Information about DSC”.
- 3) Tenderer are advised to follow the instructions provided in the ‘Instructions to the Tenderer for the e-submission of the bids online through the Central Public Procurement Portal for e Procurement at <https://eprocure.gov.in/eprocure/app> .

NOTICE INVITING QUOTATIONS

Dated: 08/09/2017

Subject: **Test rig for wheel-axle bearing health monitoring**

Invitation for Tender Offers

Indian Institute of Technology Delhi invites online Bids (Technical bid and Commercial bid) from eligible and experienced OEM (Original Equipment Manufacturer) OR OEM Authorized Dealer for **supply, installation & integration of Test rig for wheel-axle bearing health monitoring** with **minimum 2 year** on site comprehensive warranty from the date of receipt of the material as per terms & conditions specified in the tender document, which is available on CPP Portal <http://eprocure.gov.in/eprocure/app>

TECHNICAL SPECIFICATION:

A test rig for simulating a railway bogie is to be designed and fabricated. The purpose is to simulate and test measured levels of flaws in wheel bearing and wheel surface. A rough conceptual schematic of the same is shown in the figure 1. The rollers driven by electric motors (not shown) will support the wheels that simulate the railway axle wheels. The rollers themselves act as rail tracks supporting the wheels. The wheels are mounted on the axles that are in turn supported in the axle bearing boxes. The bearing box is isolated from the supporting frame using secondary suspension. Through the primary suspension, a loading mechanism applies static load on the supporting frame. The load applied should vary from 2% to 15% of the static load capacity of the bearings. The bearings of the roller should have higher bearing load capacity (at least by an order of two compared to that of wheel bearings).

The test rig should have easy means of changing the bearings of the axle. The wheels themselves are mounted on the axle (shrink fitted or otherwise with suitable arrangement). The wheel as well as roller circumference will be profiled (the way actual rail wheels are). The rig accessories include 5 sets of additional axle-wheel assemblies and 5 sets of roller assemblies. Suitable tolerances will be maintained during manufacturing so that the rotation of the wheels on the rollers simulates conditions similar to rail-wheel on track. It is important to ensure identical speed of rotation of all the rollers (within 1%). The rotational speed can vary to simulate linear speed of up to 80 kmph. The entire rig should have a 1 sq. m of footprint and noise at 2m from the center of the rig must not exceed 70 dBA.

The test rig should have a tri-axial accelerometer of a reputed make mounted on the bearing axle housing for acquiring vibration data. The vibration data and instantaneous speed will be acquired using a suitable acquisition card. Suitable load sensors for measuring load on each wheel will be built-in the rig.

The sketch is indicative and the designer/manufacturer is free to make suitable changes keeping in mind the basic requirement. The technical documentation in technical bids should include detailed calculations for complying the requirements (for example, bearing selection). The technical bid will contain detailed drawings with specifications (and tolerances), material, powering arrangements, past experience of the bidder, similar

rig supplied in the past with P.O. details. Reputed vendors with adequate knowledge and experience (in rig development/design/simulations) and track record will be preferred.

The commercial bids should have sensors and instrumentation cost separate from the rig fabrication cost. It will be mandatory for the bidder to exhibit pre-dispatch satisfactory operation continuously for minimum 4 hours.

The payment will be as per IIT Delhi payment policy (no advance payments).

In case of malfunctioning of the rig, an authorized or technician should visit IITD to sort out the problem within 72 hours.

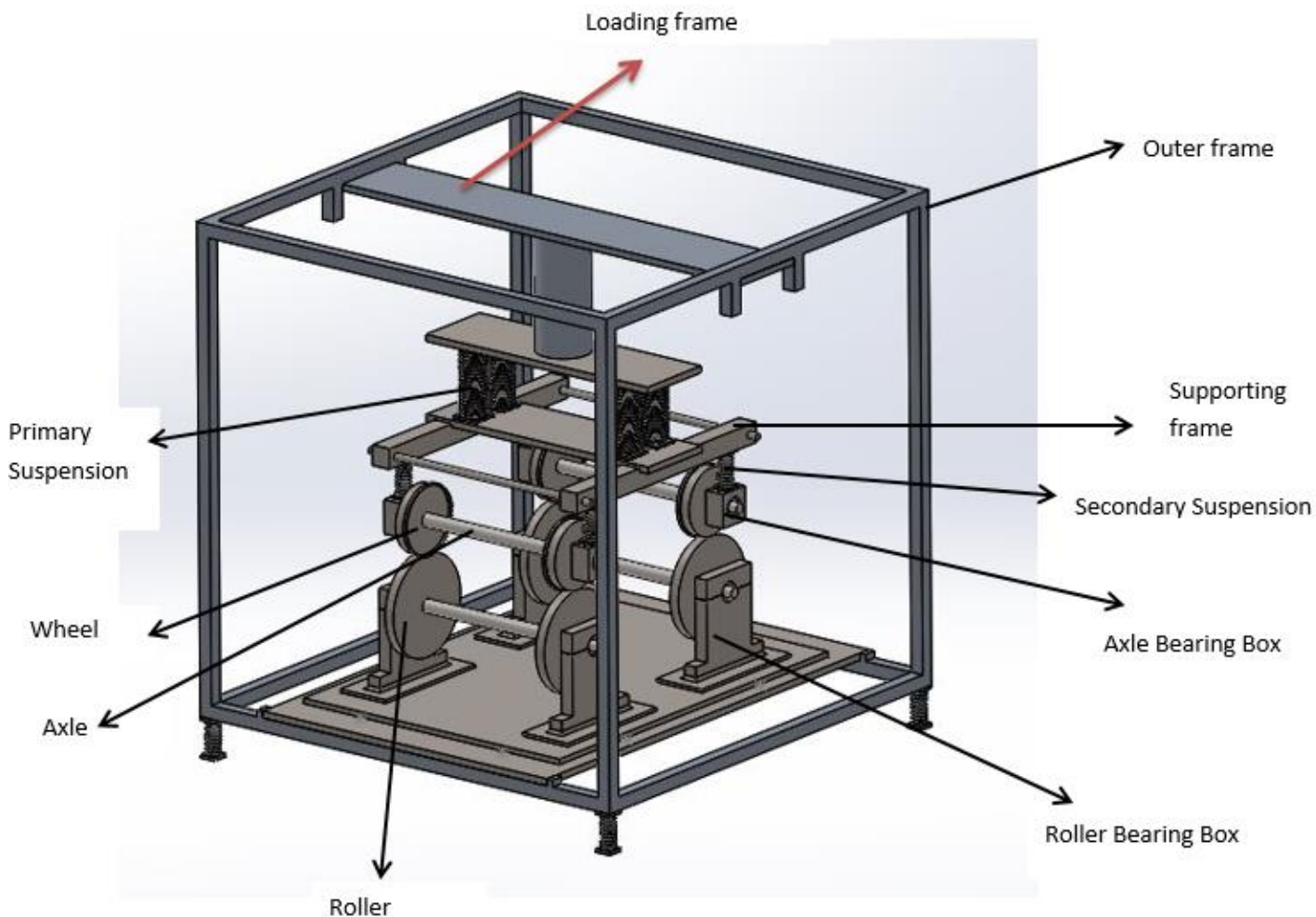

Fig. 1. Schematic of the rig for wheel-axle bearing health monitoring

A complete set of tender documents* may be Download by prospective bidder free of cost from the website <http://eprocure.gov.in/eprocure/app>. Bidder has to make payment of requisite fees (i.e. Tender fees (if any) and EMD) online through RTGS/NEFT only.

Terms & Conditions Details

| Sl. No. | Specification |
|---------|---|
| 1. | Due date: The tender has to be submitted on-line before the due date. The offers received after the due date and time will not be considered. No manual bids will be considered. |
| 2. | Preparation of Bids: The offer/bid should be submitted in two bid systems (i.e.) Technical bid and financial bid. The technical bid should consist of all technical details along with commercial terms and conditions. Financial bid should indicate item wise price for the items mentioned in the technical bid in the given format i.e Financial Bids to be submitted in PDF format. The Technical bid and the financial bid should be submitted Online. |
| 3. | EMD (if applicable): The tenderer should submit an EMD amount through RTGS/NEFT. The Technical Bid without EMD would be considered as UNRESPONSIVE and will not be accepted. The EMD will be refunded without any interest to the unsuccessful bidders after the award of contract. Refer to Schedule (at page 1 of this document) for its actual place of submission. |
| 4. | Refund of EMD: The EMD will be returned to unsuccessful Tenderer only after the Tenders are finalized. In case of successful Tenderer, it will be retained till the successful and complete installation of the equipment. |
| 5. | Opening of the tender: The online bid will be opened by a committee duly constituted for this purpose. Online bids (complete in all respect) received along with EMD (if any) will be opened as mentioned at “Annexure: Schedule” in presence of bidders representative if available. Only one representative will be allowed to participate in the tender opening. Bid received without EMD (if present) will be rejected straight way. The technical bid will be opened online first and it will be examined by a technical committee (as per specification and requirement). The financial offer/bid will be opened only for the offer/bid which technically meets all requirements as per the specification, and will be opened in the presence of the vendor’s representatives subsequently for further evaluation. The bidders if interested may participate on the tender opening Date and Time. The bidder should produce authorization letter from their company to participate in the tender opening. |
| 6. | Acceptance/ Rejection of bids: The Committee reserves the right to reject any or all offers without assigning any reason. |
| 7. | Pre-qualification criteria: (i) Bidders should be the manufacturer / authorized dealer. Letter of Authorization from original equipment manufacturer (OEM) on the same and specific to the tender should be enclosed. (ii) An undertaking from the OEM is required stating that they would facilitate the bidder on a regular basis with technology/product updates and extend support for the warranty as well. (Ref. Annexure-II) (iii) OEM should be internationally reputed Branded Company. (iv) Non-compliance of tender terms, non-submission of required documents, lack of clarity of the specifications, contradiction between bidder specification and supporting documents etc. may lead to rejection of the bid. (v) In the tender, either the Indian agent on behalf of the Principal/OEM or Principal/OEM itself can bid but both cannot bid simultaneously for the same item/product in the same tender. (vi) If an agent submits bid on behalf of the Principal/OEM, the same agent shall not submit a bid on behalf of another Principal/OEM in the same tender for the same item/product. |
| 8. | Performance Security: The supplier shall require to submit the performance security in the form of irrevocable bank guarantee issued by any Indian Nationalized Bank for an amount which is stated at page #1 of the tender document within 21 days from the date of receipt of the purchase order/LC and should be kept valid for a period of 60 days beyond the date of completion of warranty period. |
| 9. | Force Majeure: The Supplier shall not be liable for forfeiture of its performance security, liquidated damages or termination for default, if and to the extent that, it’s delay in performance or other failure to perform its obligations under the Contract is the result of an event of Force Majeure. |

| | |
|-----|--|
| | <ul style="list-style-type: none"> For purposes of this Clause, "Force Majeure" means an event beyond the control of the Supplier and not involving the Supplier's fault or negligence and not foreseeable. Such events may include, but are not limited to, acts of the Purchaser either in its sovereign or contractual capacity, wars or revolutions, fires, floods, epidemics, quarantine restrictions and freight embargoes. If a Force Majeure situation arises, the Supplier shall promptly notify the Purchaser in writing of such conditions and the cause thereof. Unless otherwise directed by the Purchaser in writing, the Supplier shall continue to perform its obligations under the Contract as far as is reasonably practical, and shall seek all reasonable alternative means for performance not prevented by the Force Majeure event. |
| 10. | Risk Purchase Clause: In event of failure of supply of the item/equipment within the stipulated delivery schedule, the purchaser has all the right to purchase the item/equipment from the other source on the total risk of the supplier under risk purchase clause. |
| 11. | Packing Instructions: Each package will be marked on three sides with proper paint/indelible ink, the following: <ol style="list-style-type: none"> Item Nomenclature Order/Contract No. Country of Origin of Goods Supplier's Name and Address Consignee details Packing list reference number |
| 12. | Delivery and Documents: Delivery of the goods should be made within a maximum of 08 to 16 weeks from the date of placement of purchase order and the opening of LC. Within 24 hours of shipment, the supplier shall notify the purchaser and the insurance company by cable/telex/fax/e mail the full details of the shipment including contract number, railway receipt number/ AAP etc. and date, description of goods, quantity, name of the consignee, invoice etc. The supplier shall mail the following documents to the purchaser with a copy to the insurance company: <ol style="list-style-type: none"> 4 Copies of the Supplier invoice showing contract number, goods' description, quantity unit price, total amount; Insurance Certificate if applicable; Manufacturer's/Supplier's warranty certificate; Inspection Certificate issued by the nominated inspection agency, if any Supplier's factory inspection report; and Certificate of Origin (if possible by the beneficiary); Two copies of the packing list identifying the contents of each package. The above documents should be received by the Purchaser before arrival of the Goods (except where the Goods have been delivered directly to the Consignee with all documents) and, if not received, the Supplier will be responsible for any consequent expenses. |
| 13. | Delayed delivery: If the delivery is not made within the due date for any reason, the Committee will have the right to impose penalty 1% per week and the maximum deduction is 10% of the contract value / price. |
| 14. | Prices: The price should be quoted in net per unit (after breakup) and must include all packing and delivery charges. The offer/bid should be exclusive of taxes and duties, which will be paid by the purchaser as applicable. However the percentage of taxes & duties shall be clearly indicated. The price should be quoted without custom duty and excise duty, since IIT Delhi is exempted from payment of Excise Duty and is eligible for concessional rate of custom duty. Necessary certificate will be issued on demand. In case of imports, the price should be quoted on FOB/FCA origin Airport Basis only. Under special circumstances (eg. perishable chemicals), when the item is imported on CIF/CIP, please indicate CIF/CIP charges separately upto IIT Delhi indicating the mode of shipment. IIT Delhi will |

| | |
|-----|---|
| | <p>make necessary arrangements for the clearance of imported goods at the Airport/Seaport. Hence the price should not include the above charges. At any circumstances, it is the responsibility of the foreign supplier to handover the material to our forwarder at the origin airport after completing all the inland clearing. No Ex- Works consignment will be entertained.</p> <p>“In case of CIF/CIP shipments, kindly provide the shipment information at least 2 days in advance before landing the shipment along with the documents i.e. invoice, packing list, forwarder Name, address, contact No. in India to save penalty/demurrage charges (imposed by Indian Customs) . Otherwise these charges will be recovered from the supplier/Indian Agent.”</p> |
| 15. | <p>Notices: For the purpose of all notices, the following shall be the address of the Purchaser and Supplier.</p> <p>Purchaser: Dr. Ashish K Darpe Mechanical Engg. Deptt. Indian Institute of Technology Hauz Khas, New Delhi - 110016.</p> <p>Supplier: (To be filled in by the supplier) (All supplier’s should submit its supplies information as per Annexure-II).</p> <p>_____</p> <p>_____</p> |
| 16. | <p>Progress of Supply: Wherever applicable, supplier shall regularly intimate progress of supply, in writing, to the Purchaser as under:</p> <ol style="list-style-type: none"> 1. Quantity offered for inspection and date; 2. Quantity accepted/rejected by inspecting agency and date; 3. Quantity dispatched/delivered to consignees and date; 4. Quantity where incidental services have been satisfactorily completed with date; 5. Quantity where rectification/repair/replacement effected/completed on receipt of any communication from consignee/Purchaser with date; 6. Date of completion of entire Contract including incidental services, if any; and 7. Date of receipt of entire payments under the Contract (In case of stage-wise inspection, details required may also be specified). |
| 17. | <p>Inspection and Tests: Inspection and tests prior to shipment of Goods and at final acceptance are as follows:</p> <ul style="list-style-type: none"> • After the goods are manufactured and assembled, inspection and testing of the goods shall be carried out at the supplier’s plant by the supplier, prior to shipment to check whether the goods are in conformity with the technical specifications attached to the purchase order. Manufacturer’s test certificate with data sheet shall be issued to this effect and submitted along with the delivery documents. The purchaser shall be present at the supplier’s premises during such inspection and testing if need is felt. The location where the inspection is required to be conducted should be clearly indicated. The supplier shall inform the purchaser about the site preparation, if any, needed for installation of the goods at the purchaser’s site at the time of submission of order acceptance. • The acceptance test will be conducted by the Purchaser, their consultant or other such person nominated by the Purchaser at its option after the equipment is installed at purchaser’s site in the presence of supplier’s representatives. The acceptance will involve trouble free operation and ascertaining conformity with the ordered specifications and quality. There shall not be any additional charges for carrying out acceptance test. No malfunction, partial or complete failure of any part of the equipment is expected to occur. The Supplier shall maintain necessary log in respect of the result of the test to establish to the entire satisfaction of the Purchaser, the successful completion of the test specified. • In the event of the ordered item failing to pass the acceptance test, a period not exceeding one weeks will be given to rectify the defects and clear the acceptance test, failing which the Purchaser reserve the right to get the equipment replaced by the Supplier at no extra cost to the Purchaser. |

| | |
|-----|--|
| | <ul style="list-style-type: none"> • Successful conduct and conclusion of the acceptance test for the installed goods and equipment shall also be the responsibility and at the cost of the Supplier. |
| 18. | <p>Resolution of Disputes: The dispute resolution mechanism to be applied pursuant shall be as follows:</p> <ul style="list-style-type: none"> • In case of Dispute or difference arising between the Purchaser and a domestic supplier relating to any matter arising out of or connected with this agreement, such disputes or difference shall be settled in accordance with the Indian Arbitration & Conciliation Act, 1996, the rules there under and any statutory modifications or re-enactments thereof shall apply to the arbitration proceedings. The dispute shall be referred to the Director, Indian Institute of Technology (IIT) Delhi and if he is unable or unwilling to act, to the sole arbitration of some other person appointed by him willing to act as such Arbitrator. The award of the arbitrator so appointed shall be final, conclusive and binding on all parties to this order. • In the case of a dispute between the purchaser and a Foreign Supplier, the dispute shall be settled by arbitration in accordance with provision of sub-clause (a) above. But if this is not acceptable to the supplier then the dispute shall be settled in accordance with provisions of UNCITRAL (United Nations Commission on International Trade Law) Arbitration Rules. • The venue of the arbitration shall be the place from where the order is issued. |
| 19. | Applicable Law: The place of jurisdiction would be New Delhi (Delhi) INDIA. |
| 20. | <p>Right to Use Defective Goods</p> <p>If after delivery, acceptance and installation and within the guarantee and warranty period, the operation or use of the goods proves to be unsatisfactory, the Purchaser shall have the right to continue to operate or use such goods until rectifications of defects, errors or omissions by repair or by partial or complete replacement is made without interfering with the Purchaser's operation.</p> |
| 21. | <p>Supplier Integrity</p> <p>The Supplier is responsible for and obliged to conduct all contracted activities in accordance with the Contract using state of the art methods and economic principles and exercising all means available to achieve the performance specified in the contract.</p> |
| 22. | <p>Training</p> <p>The Supplier is required to provide training to the designated Purchaser's technical and end user personnel to enable them to effectively operate the total equipment.</p> |
| 23. | <p>Installation & Demonstration</p> <p>The supplier is required to done the installation and demonstration of the equipment within one month of the arrival of materials at the IITD site of installation, otherwise the penalty clause will be the same as per the supply of materials.</p> <p>In case of any mishappening/damage to equipment and supplies during the carriage of supplies from the origin of equipment to the installation site, the supplier has to replace it with new equipment/supplies immediately at his own risk. Supplier will settle his claim with the insurance company as per his convenience. IITD will not be liable to any type of losses in any form.</p> |
| 24. | <p>Insurance: For delivery of goods at the purchaser's premises, the insurance shall be obtained by the supplier in an amount equal to 110% of the value of the goods from "warehouse to warehouse" (final destinations) on "All Risks" basis including War Risks and Strikes. The insurance shall be valid for a period of not less than 3 months after installation and commissioning. In case of orders placed on FOB/FCA basis, the purchaser shall arrange Insurance. If orders placed on CIF/CIP basis, the insurance should be up to IIT Delhi.</p> |
| 25. | <p>Incidental services: The incidental services also include:</p> <ul style="list-style-type: none"> • Furnishing of 01 set of detailed operations & maintenance manual. • Arranging the shifting/moving of the item to their location of final installation within IITD premises at the cost of Supplier through their Indian representatives. |
| 26. | <p>Warranty:</p> <p>(i) Warranty period shall be (as stated at page #2 of this tender) from date of installation of Goods at</p> |

| | |
|-----|--|
| | <p>the IITD site of installation. The Supplier shall, in addition, comply with the performance and/or consumption guarantees specified under the contract. If for reasons attributable to the Supplier, these guarantees are not attained in whole or in part, the Supplier shall at its discretion make such changes, modifications, and/or additions to the Goods or any part thereof as may be necessary in order to attain the contractual guarantees specified in the Contract at its own cost and expense and to carry out further performance tests. The warranty should be comprehensive on site.</p> <p>(ii) The Purchaser shall promptly notify the Supplier in writing of any claims arising under this warranty. Upon receipt of such notice, the Supplier shall immediately within in 02 days arrange to repair or replace the defective goods or parts thereof free of cost at the ultimate destination. The Supplier shall take over the replaced parts/goods at the time of their replacement. No claim whatsoever shall lie on the Purchaser for the replaced parts/goods thereafter. The period for correction of defects in the warranty period is 02 days. If the supplier having been notified fails to remedy the defects within 02 days, the purchaser may proceed to take such remedial action as may be necessary, at the supplier's risk and expenses and without prejudice to any other rights, which the purchaser may have against the supplier under the contract.</p> <p>(iii) The warranty period should be clearly mentioned. The maintenance charges (AMC) under different schemes after the expiry of the warranty should also be mentioned. The comprehensive warranty will commence from the date of the satisfactory installation/commissioning of the equipment against the defect of any manufacturing, workmanship and poor quality of the components.</p> <p>(iv) After the warranty period is over, Annual Maintenance Contract (AMC)/Comprehensive Maintenance Contract (CMC) up to next two years should be started. The AMC/CMC charges will not be included in computing the total cost of the equipment.</p> |
| 27. | <p>Governing Language The contract shall be written in English language. English language version of the Contract shall govern its interpretation. All correspondence and other documents pertaining to the Contract, which are exchanged by the parties, shall be written in the same language.</p> |
| 28. | <p>Applicable Law The Contract shall be interpreted in accordance with the laws of the Union of India and all disputes shall be subject to place of jurisdiction.</p> |
| 29. | <p>Notices</p> <ul style="list-style-type: none"> • Any notice given by one party to the other pursuant to this contract/order shall be sent to the other party in writing or by cable, telex, FAX or e mail and confirmed in writing to the other party's address. • A notice shall be effective when delivered or on the notice's effective date, whichever is later. |
| 30. | <p>Taxes Suppliers shall be entirely responsible for all taxes, duties, license fees, octroi, road permits, etc., incurred until delivery of the contracted Goods to the Purchaser. However, VAT in respect of the transaction between the Purchaser and the Supplier shall be payable extra, if so stipulated in the order.</p> |
| 31. | <p>Duties IIT Delhi is exempted from paying custom duty under notification No.51/96 (partially or full) and necessary "Custom Duty Exemption Certificate" can be issued after providing following information and Custom Duty Exemption Certificate will be issued to the shipment in the name of the Institute, (no certificate will be issued to third party): The procured product should be used for teaching, scientific and research work only.</p> <p>a) Shipping details i.e. Master Airway Bill No. and House Airway No. (if exists) b) Forwarder details i.e. Name, Contact No., etc.</p> <p>IIT Delhi is exempted from paying Excise Duty and necessary Excise Duty Exemption Certificate will be provided for which following information are required.</p> <p>b) Quotation with details of Basic Price, Rate, Tax & Amount on which ED is applicable</p> |

| | |
|-----|---|
| | c) Supply Order Copy d) Proforma-Invoice Copy. |
| 32. | Agency Commission: Agency commission if any will be paid to the Indian agent in Rupees on receipt of the equipment and after satisfactory installation. Agency Commission will not be paid in foreign currency under any circumstances. The details should be explicitly shown in Tender even in case of Nil commission. The tenderer should indicate the percentage of agency commission to be paid to the Indian agent. |
| 33. | Payment: (i) For imported items Payment will be made through irrevocable Letter of Credit (LC) Cash Against Documents (CAD)/Against delivery/after satisfactory installation by T.T. Letter of Credit (LC) will be established in favour of foreign Supplier after the submission of performance security. The letter of credit (LC) will be established on the exchange rates as applicable on the date of establishment. For Imports, LC will be opened for 100% FOB/CIF value. 80% of the LC amount shall be released on presentation of complete and clear shipping documents and 20% of the LC amount shall be released after the installation and demonstration of the equipment at the INST site of installation in faultless working condition for period of 60 days from the date of the satisfactory installation and subject to the production of unconditional performance bank guarantee as specified in Clause 8 of tender terms and conditions. (ii) For Indigenous supplies, 100% payment shall be made by the Purchaser against delivery, inspection, successful installation, commissioning and acceptance of the equipment at IITD in good condition and to the entire satisfaction of the Purchaser and on production of unconditional performance bank guarantee as specified in Clause 9 of tender terms and conditions. (iii) Indian Agency commission (IAC), if any shall be paid after satisfactory installation & commissioning of the goods at the destination at the exchange rate prevailing on the date of negotiation of LC documents, subject to DGS&D registration for restricted items. (iv) All the bank charges within India will be borne by the Institute and outside India will be borne by the Supplier. |
| 34. | User list: Brochure detailing technical specifications and performance, list of industrial and educational establishments where the items enquired have been supplied must be provided. (Ref. Annexure-III) |
| 35. | Manuals and Drawings (i) Before the goods and equipment are taken over by the Purchaser, the Supplier shall supply operation and maintenance manuals. These shall be in such details as will enable the Purchaser to operate, maintain, adjust and repair all parts of the works as stated in the specifications. (ii) The Manuals shall be in the ruling language (English) in such form and numbers as stated in the contract. (iii) Unless and otherwise agreed, the goods equipment shall not be considered to be completed for the purposes of taking over until such manuals and drawing have been supplied to the Purchaser. |
| 36. | Application Specialist: The Tenderer should mention in the Techno-Commercial bid the availability and names of Application Specialist and Service Engineers in the nearest regional office. (Ref. to Annexure-III) |
| 37. | Site Preparation: The supplier shall inform to the Institute about the site preparation, if any, needed for the installation of equipment, immediately after the receipt of the purchase order. The supplier must provide complete details regarding space and all the other infrastructural requirements needed for the equipment, which the Institute should arrange before the arrival of the equipment to ensure its timely installation and smooth operation thereafter. The supplier shall visit the Institute and see the site where the equipment is to be installed and may offer his advice and render assistance to the Institute in the preparation of the site and other pre-installation requirements. |
| 38. | Spare Parts The Supplier may be required to provide any or all of the following materials, notifications, and |

| | |
|-----|---|
| | <p>information pertaining to spare parts manufactured or distributed by the Supplier:</p> <ul style="list-style-type: none"> ii. Such spare parts as the Purchaser may elect to purchase from the Supplier, providing that this election shall not relieve the Supplier of any warranty obligations under the Contract; and iii. In the event of termination of production of the spare parts: iv. Advance notification to the Purchaser of the pending termination, in sufficient time to permit the Purchaser to procure needed requirements; and v. Following such termination, furnishing at no cost to the Purchaser, the blueprints, drawings and specifications of the spare parts, if requested. <p>Supplier shall carry sufficient inventories to assure ex-stock supply of consumable spares for the Goods, such as gaskets, plugs, washers, belts etc. Other spare parts and components shall be supplied as promptly as possible but in any case within six months of placement of order.</p> |
| 39. | <p>Defective Equipment: If any of the equipment supplied by the Tenderer is found to be substandard, refurbished, un-merchantable or not in accordance with the description/specification or otherwise faulty, the committee will have the right to reject the equipment or its part. The prices of such equipment shall be refunded by the Tenderer with 18% interest if such payments for such equipment have already been made. All damaged or unapproved goods shall be returned at suppliers cost and risk and the incidental expenses incurred thereon shall be recovered from the supplier. Defective part in equipment, if found before installation and/or during warranty period, shall be replaced within 45 days on receipt of the intimation from this office at the cost and risk of supplier including all other charges. In case supplier fails to replace above item as per above terms & conditions, IIT Delhi may consider "Banning" the supplier.</p> |
| 40. | <p>Termination for Default</p> <p>The Purchaser may, without prejudice to any other remedy for breach of contract, by written notice of default sent to the Supplier, terminate the Contract in whole or part:</p> <ul style="list-style-type: none"> i. If the Supplier fails to deliver any or all of the Goods within the period(s) specified in the order, or within any extension thereof granted by the Purchaser; or ii If the Supplier fails to perform any other obligation(s) under the Contract. iii If the Supplier, in the judgment of the Purchaser has engaged in corrupt or fraudulent practices in competing for or in executing the Contract. <ul style="list-style-type: none"> ● For the purpose of this Clause: <ul style="list-style-type: none"> i. “Corrupt practice” means the offering, giving, receiving or soliciting of anything of value to influence the action of a public official in the procurement process or in contract execution. ii. “Fraudulent practice” means a misrepresentation of facts in order to influence a procurement process or the execution of a contract to the detriment of the Borrower, and includes collusive practice among Bidders (prior to or after bid submission) designed to establish bid prices at artificial non-competitive levels and to deprive the Borrower of the benefits of free and open competition;” ● In the event the Purchaser terminates the Contract in whole or in part, the Purchaser may procure, upon such terms and in such manner, as it deems appropriate, Goods or Services similar to those undelivered, and the Supplier shall be liable to the Purchaser for any excess costs for such similar Goods or Services. However, the Supplier shall continue the performance of the Contract to the extent not terminated. |
| 41. | <p>Shifting: After 1-2 years once our new Academic Block will be ready, the supplier has to shift and reinstall the instrument free of cost (if required).</p> |
| 42. | <p>Downtime: During the warranty period not more than 5% downtime will be permissible. For every day exceeding permissible downtime, penalty of 1/365 of the 5% FOB value will be imposed. Downtime will be counted from the date and time of the filing of complaint with in the business hours.</p> |
| 43. | <p>Training of Personnel: The supplier shall be required to undertake to provide the technical training</p> |

| | |
|-----|--|
| | to the personnel involved in the use of the equipment at the Institute premises, immediately after completing the installation of the equipment for a minimum period of one week at the supplier's cost. |
| 44. | Disputes and Jurisdiction: Any legal disputes arising out of any breach of contract pertaining to this tender shall be settled in the court of competent jurisdiction located within New Delhi. |
| 45. | Compliance certificate: This certificate must be provided indicating conformity to the technical specifications. (Annexure-I) |

COMPLIANCE SHEET

TECHNICAL SPECIFICATION

| S.NO. | TECHNICAL SPECIFICATION | COMPLIANCE Y/N |
|-------|---|-------------------|
| 1. | <p>A test rig for simulating a railway bogie is to be designed and fabricated. The purpose is to simulate and test measured levels of flaws in wheel bearing and wheel surface. A rough conceptual schematic of the same is shown in the figure 1. The rollers driven by electric motors (not shown) will support the wheels that simulate the railway axle wheels. The rollers themselves act as rail tracks supporting the wheels. The wheels are mounted on the axles that are in turn supported in the axle bearing boxes. The bearing box is isolated from the supporting frame using secondary suspension. Through the primary suspension, a loading mechanism applies static load on the supporting frame. The load applied should vary from 2% to 15% of the static load capacity of the bearings. The bearings of the roller should have higher bearing load capacity (at least by an order of two compared to that of wheel bearings).</p> <p>The test rig should have easy means of changing the bearings of the axle. The wheels themselves are mounted on the axle (shrink fitted or otherwise with suitable arrangement). The wheel as well as roller circumference will be profiled (the way actual rail wheels are). The rig accessories include 5 sets of additional axle-wheel assemblies and 5 sets of roller assemblies. Suitable tolerances will be maintained during manufacturing so that the rotation of the wheels on the rollers simulates conditions similar to rail-wheel on track. It is important to ensure identical speed of rotation of all the rollers (within 1%). The rotational speed can vary to simulate linear speed of up to 80 kmph. The entire rig should have a 1 sq. m of footprint and noise at 2m from the center of the rig must not exceed 70 dBA.</p> <p>The test rig should have a tri-axial accelerometer of a reputed make mounted on the bearing axle housing</p> | |

for acquiring vibration data. The vibration data and instantaneous speed will be acquired using a suitable acquisition card. Suitable load sensors for measuring load on each wheel will be built-in the rig.

The sketch is indicative and the designer/manufacturer is free to make suitable changes keeping in mind the basic requirement. The technical documentation in technical bids should include detailed calculations for complying the requirements (for example, bearing selection). The technical bid will contain detailed drawings with specifications (and tolerances), material, powering arrangements, past experience of the bidder, similar rig supplied in the past with P.O. details. Reputed vendors with adequate knowledge and experience (in rig development/design/simulations) and track record will be preferred.

The commercial bids should have sensors and instrumentation cost separate from the rig fabrication cost. It will be mandatory for the bidder to exhibit pre-dispatch satisfactory operation continuously for minimum 4 hours.

The payment will be as per IIT Delhi payment policy (no advance payments).

In case of malfunctioning of the rig, an authorized or technician should visit IITD to sort out the problem within 72 hours.

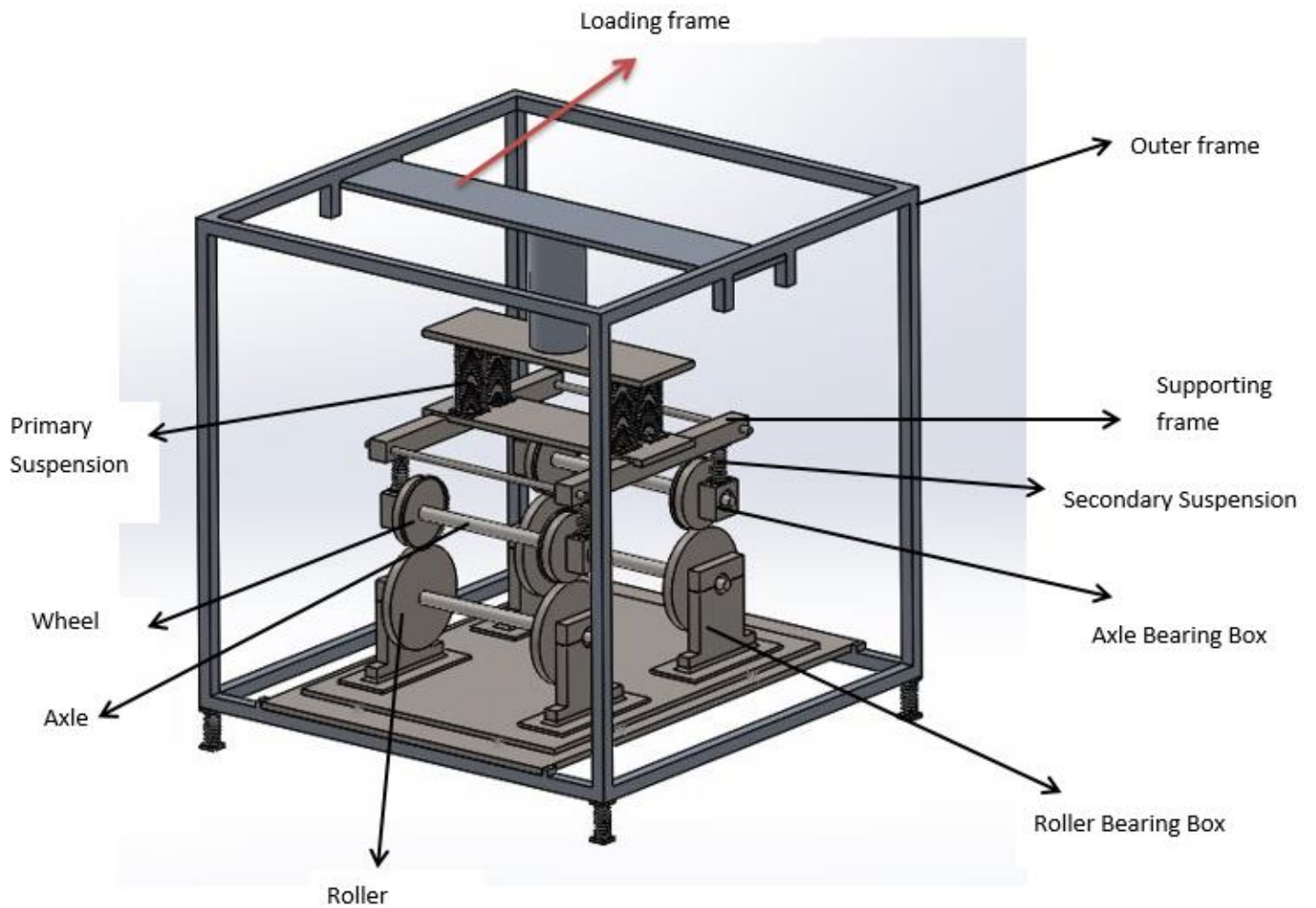

Fig. 1. Schematic of the rig for wheel-axle bearing health monitoring

I have also enclosed all relevant documents in support of my claims, (as above) in the following pages.

Signature of Bidder

Name: _____

Designation: _____

Organization Name: _____

Contact No. : _____

**<< Organization Letter Head >>
DECLARATION SHEET**

We, _____ hereby certify that all the information and data furnished by our organization with regard to this tender specification are true and complete to the best of our knowledge. I have gone through the specification, conditions and stipulations in details and agree to comply with the requirements and intent of specification.

This is certified that our organization has been authorized (Copy attached) by the OEM to participate in Tender. We further certified that our organization meets all the conditions of eligibility criteria laid down in this tender document. Moreover, OEM has agreed to support on regular basis with technology / product updates and extend support for the warranty.

The prices quoted in the financial bids are subsidized due to academic discount given to IIT Delhi.

| | |
|--|---|
| We, further specifically certify that our organization has not been Black Listed/De Listed or put to any Holiday by any Institutional Agency/ Govt. Department/ Public Sector Undertaking in the last three years. | NAME & ADDRESS OF THE Vendor/ Manufacturer / Agent |
| 1 Phone | |
| 2 Fax | |
| 3 E-mail | |
| 4 Contact Person Name | |
| 5 Mobile Number | |
| 6 TIN Number | |
| 7 PAN Number | |
| (In case of on-line payment of Tender Fees) | |
| 8 UTR No. (For Tender Fee) | |
| (In case of on-line payment of EMD) | |
| 9 UTR No. (For EMD) | |
| 10 Kindly provide bank details of the bidder in the following format: a) Name of the Bank | |
| b) Account Number | |
| c) Kindly attach scanned copy of one Cheque book page to enable us to return the EMD to unsuccessful bidder | |

(Signature of the Tenderer)

Name:

Seal of the Company

Bid Submission

Online Bid Submission:

The Online bids (complete in all respect) must be uploaded online in **two** Envelops as explained below:-

| Envelope – 1 | | | |
|---|---------------|--|------------|
| (Following documents to be provided as single PDF file) | | | |
| Sl. No. | Documents | Content | File Types |
| 1. | Technical Bid | Compliance Sheet as per Annexure - I | .PDF |
| 2. | | Organization Declaration Sheet as per Annexure - II | .PDF |
| 3. | | List of organizations/ clients where the same products have been supplied (in last two years) along with their contact number(s). (Annexure-III) | .PDF |
| 4. | | Technical supporting documents in support of all claims made at Annexure-I (Annexure-IV) | .PDF |
| Envelope – 2 | | | |
| Sl. No. | TYPES | Content | |
| 1. | Financial Bid | Price bid should be submitted in PDF format. | .PDF |

**<Department/Centre Name>
Indian Institute of Technology Delhi
Hauz Khas, New Delhi-110016**

Date: XX/XX/XXXX

Subject: Purchase of <Item> (Following format is used for imported items)

| S. No. | Currency | Description and Specification of the Item | Qty. in Units | Unit Price (a) | Agency Commission (If applicable) (b) | Discount (c) | Ex-works price (d=a+b-c) | Packing + Handling + DOC + Inland Freight + FCA Charges (e) | FOB/FCA Airport Price (f=d+e) | Insurance + Freight (g) | CIF Price (f+g) |
|--------|----------|---|---------------|----------------|---------------------------------------|--------------|--------------------------|---|-------------------------------|-------------------------|-----------------|
| 1 | | | | | | | | | | | |

Note: At any circumstances, it is the responsibility of the foreign supplier to hand over the material to our forwarder at the origin airport after completing all the inland clearing. No Ex-works consignment will be entertained.

For indigenous items please quote as per following format.

| S. No. | Description and Specification of the Item | Qty. in Units | Unit Price in Rs. | GST% | Total Price in Rs. |
|--------|---|---------------|-------------------|------|--------------------|
| 1. | | | | | |
| 2. | | | | | |

Note: The above financial template should be strictly followed. Any deviation from the above template (in terms of description and specification of the item) may lead to cancellation of the tender.