

**INDIAN INSTITUTE OF TECHNOLOGY DELHI
HAUZ KHAS NEW DELHI**

Date: 25.02.2016

Notice Inviting Quotation

Quotations are invited for the purchase of **one set of accessories for TOYOTA water-jet loom**, for the Department of Textile Technology. Interested suppliers are required to submit their quotations as per the specifications given below. The sealed Quotations are to be submitted in two Separate envelopes;

**A - for Technical Quote (Specifications) &
B - for Financial Quote
(For details, see Annexure I)**

Both these envelopes should be further enclosed in an outer envelope, which should also be sealed and addressed to, clearly mentioning on top right corner of the envelope "quotations for **Vacuum Oven**"

**Dr. Abhijit Majumdar
Associate Professor
Room No. TX-212/TX-117
Department of Textile Technology
IIT, Hauz Khas, New Delhi 110016**

The quotations should reach the above office by **4.00PM on 11/03/2016**. If needed, the suppliers may be asked to make a technical presentation/demonstration of the equipment before the committee.

Institute reserves the right to accept or reject any of the offers without assigning any reasons.

Specifications for accessories of water-jet loom (see the drawing for details)

1. **Warp beam (TOYOTA waterjet loom LWT710)**
2. **Cloth beam (TOYOTA waterjet loom LWT710)**
3. **Heald wires (TOYOTA waterjet loom LWT710)**
4. **Reed (TOYOTA waterjet loom LWT710)**
5. **Complete water supply system (Pump for water-jet loom, piping, water tank and water softening treatment etc.)**

Warranty (one year)

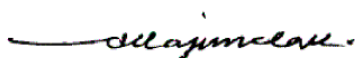

Abhijit Majumdar

Annexure I

Envelope A: Technical Quote: The following details are to be enclosed (*Mention clearly on this envelope – Technical Quote*)

1. Technical brochures mentioning all details with complete address of the principals.
2. A compliance chart based on the specifications as per the NIQ.
3. Any optional equipment / accessory / spares advised to be included separately.
4. Installation requirements including gases and chillers, UPS, etc.
5. List and addresses of organizations where the equipment has been supplied in last 3 years in India.
6. Address of the technical office, in India, with telephone and FAX numbers. Kindly clarify the type of support available in India.
7. Proprietary Item Certificate from the principals, if applicable.

Envelope B: Financial Quote: The following details are to be enclosed/ ensured. (*Mention clearly on this envelope – Financial Quote*)

1. The quotations for the equipment in foreign exchange, if it is to be imported. The cost of spares and optional equipment/accessories to be quoted separately. The cost should be based on CIF, New Delhi. If equipment is indigenous, the quote should be in INR and all taxes applicable should be mentioned clearly.
2. Institute makes payment after delivery and successful installation. In case the payment terms are different, it should be mentioned clearly. If equipment is to be imported, the address of the company in whose name the LC is to be opened should be stated.
3. The comprehensive Warranty period.
4. The details of the AMC after the warranty period.
5. Cost for Installation and training at site, if applicable.
6. Validity of the quote should be minimum 90 days.
7. The delivery period to be clearly specified.

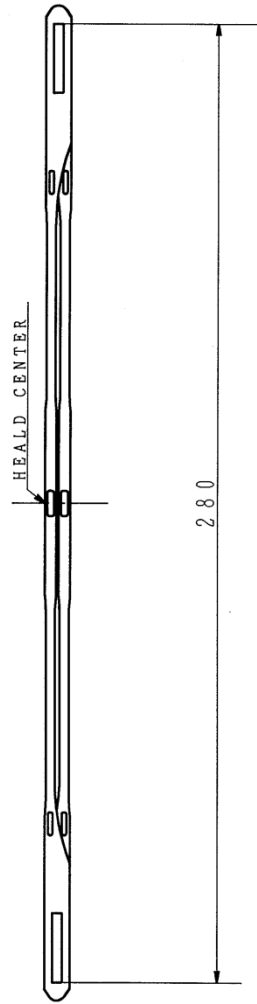

Heald wire

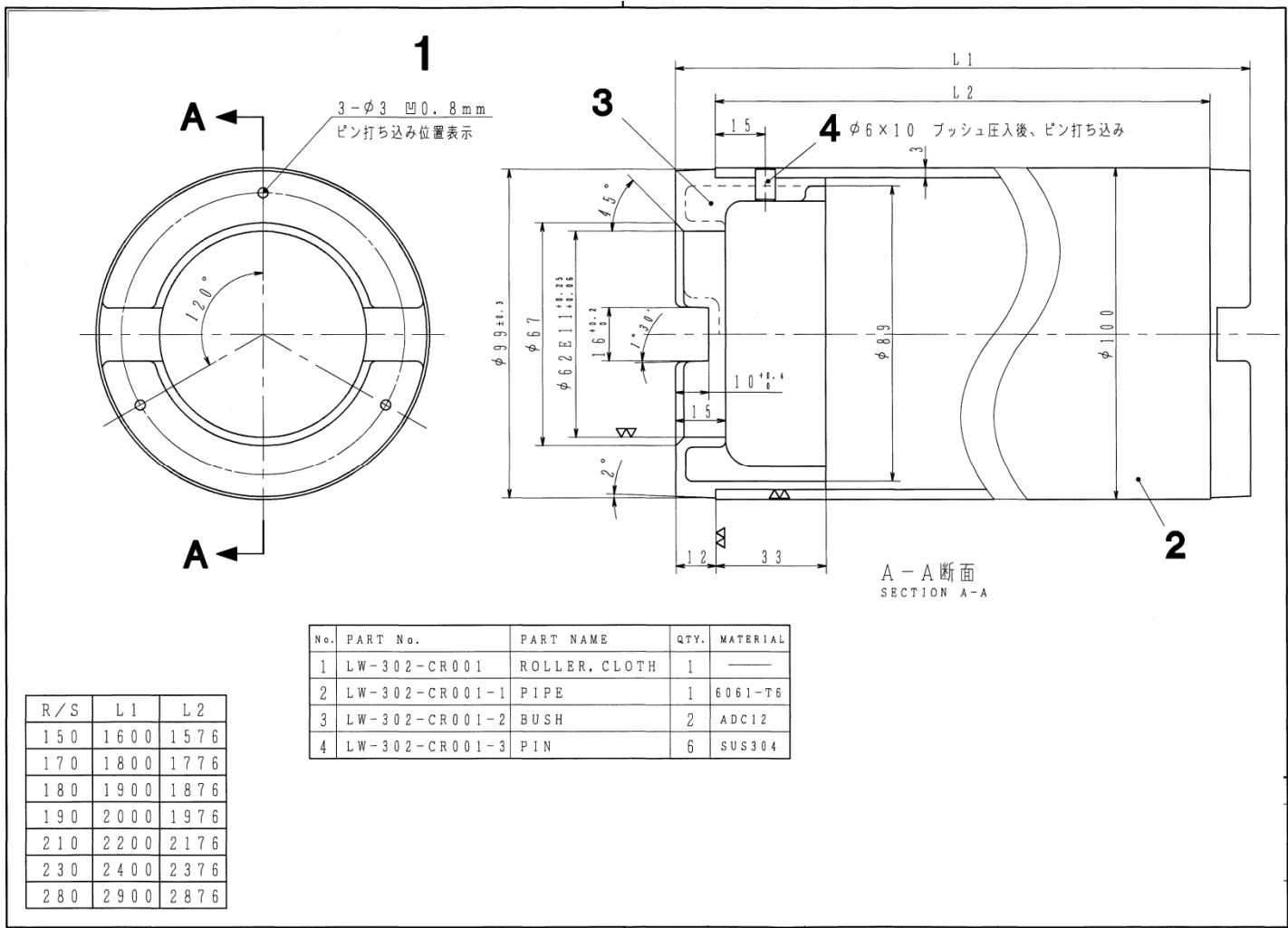

No.	PART No.	PART NAME	QTY.	MATERIAL
1	LW-302-CR001	ROLLER, CLOTH	1	—
2	LW-302-CR001-1	PIPE	1	6061-T6
3	LW-302-CR001-2	BUSH	2	ADC12
4	LW-302-CR001-3	PIN	6	SUS304

R/S	L1	L2
150	1600	1576
170	1800	1776
180	1900	1876
190	2000	1976
210	2200	2176
230	2400	2376
280	2900	2876

Cloth roller

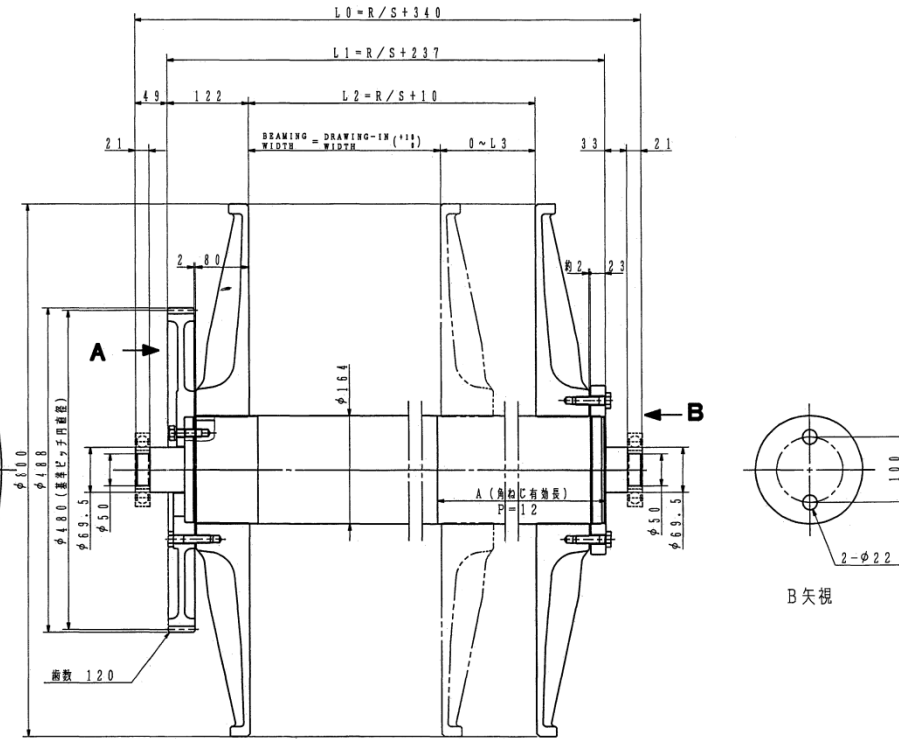
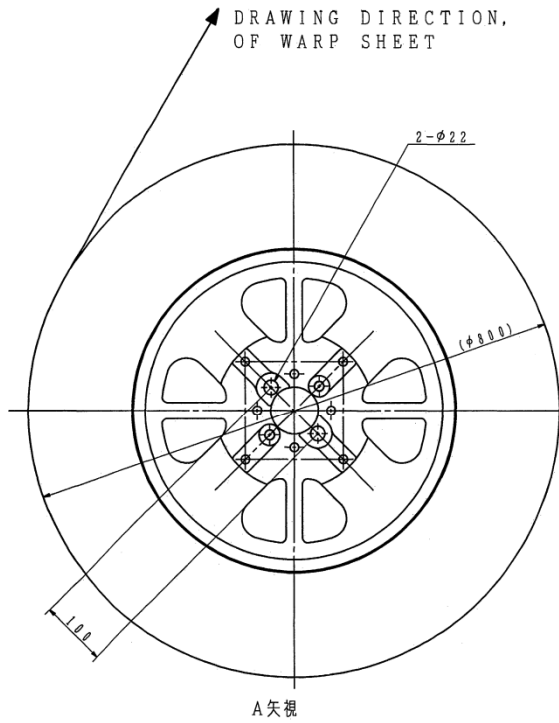

R/S	L0	L1	L2	L3	A
150	1840	1737	1510	600	725
170	2040	1937	1710	600	725
180	2140	2037	1810	600	725
190	2240	2137	1910	800	925
210	2440	2337	2110	800	925
230	2640	2537	2310	800	925

Warp beam

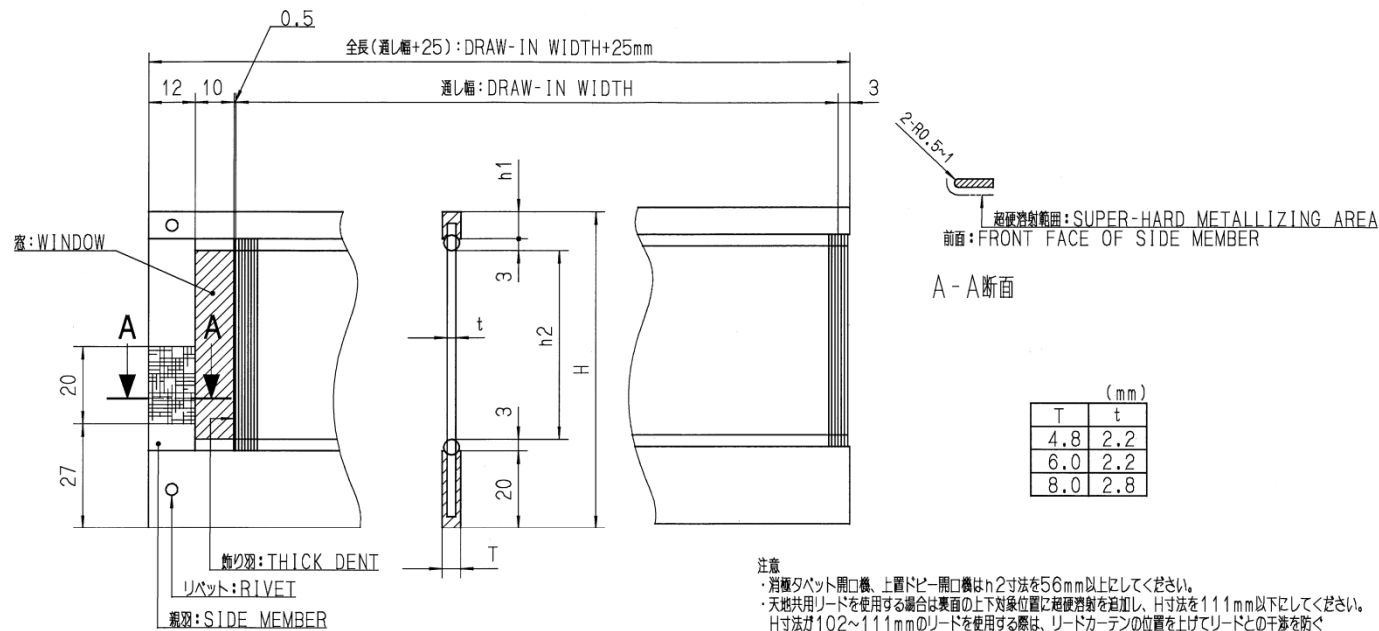

(mm)

T	t
4.8	2.2
6.0	2.2
8.0	2.8

リード: REED	H	h1	h2	備考: REMARKS
標準 : STANDARD	82	7	49	クランク開口機用: FOR CRANK SHEDDING MOTION LW600リードストローク75mm用を共用 : IDENTICAL WITH LW600 REED STROKE 75mm TYPE
	89		56	LW600リードストローク85mm用を共用 : IDENTICAL WITH LW600 REED STROKE 85mm TYPE
天地共用 : REVERSIBLE	95	20	49	クランク開口機用: FOR CRANK SHEDDING MOTION LW600リードストローク75mm用を共用 : IDENTICAL WITH LW600 REED STROKE 75mm TYPE
	102		56	LW600リードストローク85mm用を共用 : IDENTICAL WITH LW600 REED STROKE 85mm TYPE

注意
 ・若線タペット開口機、上置ドビー開口機はh2寸法を56mm以上にしてください。
 ・天地共用リードを使用する場合は裏面の上下対称位置に超硬溶射を追加し、H寸法を111mm以下にしてください。
 H寸法が102~111mmのリードを使用する際は、リードカーテンの位置を上げてリードとの干渉を防ぐ
 必要があります。

NOTE
 ・IN CASE OF NEGATIVE TAPPET CAM SHEDDING MOTION AND
 UPPER DOBBY SHEDDING MOTION, DIMENSION h2 SHOULD BE
 LONGER THAN 56mm.
 ・WHEN A REVERSIBLE REED IS USED, ADD SUPER-HARD
 METALLIZING TO THE SYMMETRICAL PORTIONS AT THE TOP
 AND BOTTOM ON THE REAR SIDE AND DIMENSION H SHOULD BE
 111mm OR UNDER.
 WHEN USING REEDS WITH DIMENSION H 102~111mm,
 THE POSITION OF THE REED CURTAIN SHOULD BE RAISED TO
 PREVENT INTERFERENCE WITH REEDS.

Reed

Pump type	Pumped water q'ty (cc/pick)	Loom speed (rpm)							
		600	650	700	750	800	850	900	1000
16	2.41	83.3	90.2	97.2	104.1	111.1	118.0	124.9	138.8
		2.00	2.17	2.33	2.50	2.67	2.83	3.00	3.33
18	3.05	105.4	114.2	123.0	131.8	140.5	149.3	158.1	175.7
		2.53	2.74	2.95	3.16	3.37	3.58	3.79	4.21
20	3.77	130.3	141.2	152.0	162.9	173.7	184.6	195.4	217.1
		3.13	3.39	3.65	3.91	4.17	4.43	4.69	5.21
22	4.56	157.6	170.7	183.9	197.0	210.1	223.3	236.4	262.7
		3.78	4.10	4.41	4.73	5.04	5.36	5.67	6.30
24	5.43	187.7	203.3	218.9	234.6	250.2	265.9	281.5	312.8
		4.50	4.88	5.25	5.63	6.01	6.38	6.76	7.51
26	6.36	219.8	238.1	256.4	274.8	293.1	311.4	329.7	366.2
		5.28	5.71	6.15	6.59	7.03	7.47	7.91	8.79

Pump type 18 is needed for our machine