

**INDIAN INSTITUTE OF TECHNOLOGY DELHI
HAUZ KHAS, NEW DELHI-110016**

Index of Tender documents

Sr. No.	DETAILS	PAGE NO.
1.	Index	1-1
2.	Details & Online Instruction	2-3
3.	Tender Notice	4-6
4.	Form "F"	7-7
5.	Terms & condition including IIT Form 6-7/8	8-41
6.	Make List	42-43
7.	Additional conditions and Special term & Condition	44-45
8.	Chair Fixing Procedure and Annexure IV	46-47
9.	Corrections slips	48-52
10.	Bid Submission	53-53
11.	Schedule of Quantities	54-67

This Tender documents contains pages Sixty Seven Only.

NIT Amounting to Rs. 1, 58, 97,785/- (Rupees One Crore Fifty Eight Lakh Ninety Seven Thousand Seven Hundred Eighty Five Only)

Institute Engineer

Notice Inviting E-Tender (E-Procurement mode)
INDIAN INSTITUTE OF TECHNOLOGY DELHI
HAUZ KHAS, NEWDELHI-110016

Dated:- 15/09/2020

Open Tender Notice No. IITD/ WORKS/(SP-3153)/2020
--

Indian Institute of Technology Delhi is in the process of purchasing following item(s)/ services as per details as given as under.

Details of the item	Name of work: - Renovation and Modification of Seminar Hall in academic area at IIT Delhi. Sub Head: - Civil, Electrical, & Furniture Work.
Earnest Money Deposit submitted	Rs. 3,17,956/-
Warranty / Maintenance Period	1 Year
Performance Security	5% of Tender Amount

Tender Documents may be downloaded from Central Public Procurement Portal <http://eprocure.gov.in/eprocure/app>

Aspiring Bidders who have not enrolled/registered in e-procurement should enroll/register before participating through the website <http://eprocure.gov.in/eprocure/app>. The portal enrolment is free of cost. Bidders are advised to go through instructions provided at 'Instructions for online Bid Submission'.

Tender can access tender documents on the website (For searching in the NIC site, kindly go to Tender Search option and type 'IIT'. Thereafter, Click on "GO" button to view all IIT Delhi tenders). Select the appropriate tender and fill them with all relevant information and submit the completed tender document online on the website <http://eprocure.gov.in/eprocure/app> as per the schedule given in the next page.

No manual bids will be accepted. All quotation (both Technical and Financial should be submitted in the e-procurement portal)

NOTICE INVITING E-TENDERS

Executive Engineer (CD-III) Indian Institute of Technology, Hauz Khas, New Delhi-16. (Phone No. 011-26596237) on behalf of Board of Governors invites online **Item Rate Tender** from Firms/ Contractors Registered in appropriate class and category with CPWD, MES, BSNL, and Railways for the following work:

1. NIT No : **/IITD/EE(CD-III)/2020-2021**
2. Name of Work : Renovation and Modification of Seminar Hall in academic area at IIT Delhi.
Sub Head : Civil, Electrical & Furniture Work.
3. Estimated cost : **Rs. 1,58,97,785/-**
4. Earnest Money : **Rs. 3,17,956/-**
5. Period of completion : **05 Months**
6. Last time& date of submission of bid: **24/09/2020 up to 3:00 pm (on line)**

The bid forms and other details can be obtained from the website **www.iitd.ac.in** or **e-procure.gov.in** free of cost. For more clarification you may visit on above website.

**Executive Engineer (CD-III),
For & on Behalf of BOG, IIT Delhi**

Ch. Head: PLN-12/01B
Work code- WO3490

Copy to: -

1. Institute Engineer
2. Executive Engineer (CD-III) for information.
3. D.A. (Works Accounts)
4. AEE (C)
5. D.R. (A/Cs) – for opening of uploaded documents **at 11:00 AM 25/09/2020** in the office of D.R. Store
6. Notice Boards.
7. Office Copy
8. Web site Administrator, I.I.T.D.

INDIAN INSTITUTE OF TECHNOLOGY: DELHI
HAUZ KHAS: NEW DELHI – 110016

INFORMATION AND INSTRUCTIONS FOR BIDDERS FOR e-TENDERING (Tender Notice)

The Executive Engineer (CD-III), IIT DELHI, HAUZ KHAS, New Delhi-16 (Phone No 011-26596237) on behalf of Board of Governors invite online **Item Rate Tender** from Firms/ Contractors Registered in appropriate class and category with CPWD, MES, BSNL, and Railways for **Composite works** of the following work:

SL. No.	NIT No.	Name of Work	Estimated Cost (in Rs.)	Earnest Money (in Rs.)	Tender Fees (in Rs.)	Time for completion
1	/IITD/EE(CD-III)/2020-2021.	Name of work: Renovation and modification of Seminar Hall in academic area at IIT Delhi. Sub Head :- Civil, Electrical & Furniture Work.	1,58,97,785/-	3,17,956/-	1500/-	05 Months

Last date and time of submission of financial & Technical bid :- 24/09/2020 upto 3:00 pm (on line)

Date and time of opening of Technical bid :- 25/09/2020 upto 03.00 pm (office of D.R Store)

Price bids of eligible bidders as per NIT shall be opened at a later date after scrutiny of Technical bids.

- The successful bidders shall be required to submit a performance guarantee of 5% of the tendered amount in the form of Bank Guarantee or F.D.R. from a Nationalized/Scheduled Bank within 15 days of issue of letter of intent before award of work. In case of failure by the Contractor to supply the performance guarantee within the specified period, full earnest money will be forfeited and the tender shall be treated as void. The performance guarantee shall be initially valid up to the stipulated date of completion plus 60 (Sixty) days beyond that.
- Contractors who fulfill the following requirements shall be eligible to apply. Joint ventures are not accepted.
 - Firms/Contractors must have completed satisfactorily one similar work of value not less than Rs. 1,27,18,228/- or Two similar works each of value not less than Rs. 95,38,671/- or three similar works each of value not less than Rs 63,59,114/- during last 7 years ending on date 31-08-2020.**
 - Earnest money of Rs. 3,17,956/-** in the form of Banker's cheque or Demand draft or fixed deposit receipt of a schedule bank drawn in favour of **Registrar, I.I.T. Delhi** or through RTGS/NEFT as per detail given on page-09. No relaxation in EMD will be allowed for MSMEs and MSEs as per CPWD Manual.
- The intending bidder must read the terms and conditions of IITD-6 carefully. He should only submit his bid if he considers himself eligible and he is in possession of all the documents required.
- Information and Instructions for bidders posted on website shall form part of bid document.
- The bid document consisting of plans, specifications, the schedule of quantities of various types of items to be executed and the set of terms and conditions of the contract to be complied with and other necessary documents can be seen and downloaded from website <http://eprocure.gov.in/eprocure/app> in free of cost.
- Completion certificates issued by an officer not below the rank of Executive Engineer of similar works completed by the Agency.
- Work means only work under Government/ Public Sector Under taking / Autonomous bodies.
- Similar work means composite works of maintenance of buildings/ Renovation/ Addition Alteration/ Rehabilitation/ New construction of buildings (Each work shall be inclusive of Civil, Electrical & Furniture work).

9. The value of executed work shall be brought to current costing level by enhancing the actual value of work at simple rate of 7% per annum calculated from the date of completion to last date of submission of financial bid.
10. IITD is committed to follow the principle of transparency, equity and competitiveness in public procurement. Before submission of bid each bidder should sign integrity pact at respective places and submit the bid, if duly signed integrity pact is not submitted by bidder such bid shall not be considered.
11. Those contractors not registered on the website mentioned above, are required to get registered beforehand. If needed they can be imparted training on online bidding process as per details available on the website
12. The intending bidder must have valid class-III digital signature to submit the bid.
13. On opening date, the contractor can login and see the bid opening process. After opening of bids he will receive the competitor bid sheets.
14. Contractor can upload documents in the form of JPG format and PDF format.
15. Contractor must ensure to quote rate of each item, while selecting any of the cells a warning appears that if any cell is left blank the same shall be treated as "0". Therefore, if any cell is left blank and no rate is quoted by the bidder, rate of such item shall be treated as "0" (ZERO).
16. The department reserves the right to reject any prospective application without assigning any reason and to restrict the list of qualified contractors to any number deemed suitable by it, if too many bids are received satisfying the laid down criterion.
17. In e-Tendering intending bidder can quote his rates in figures only. The rates in words, amount of each item and total is generated automatically. Therefore, the rate quoted by the bidder in figures is to be taken as correct.
18. The bid can only be submitted after uploading the mandatory scanned documents such as Demand Draft or Pay order or Banker`s Cheque or Deposit at call Receipt or Fixed Deposit Receipts and towards cost of EMD in favour of **Registrar IIT Delhi** to be deposited with <http://eprocure.gov.in/eprocure/app> / NEFT facility.
19. The physical EMD of the scanned copy of EMD uploaded shall be deposited by the lowest tenderer within a week after opening of financial bid failing which the tender shall be rejected.
20. The following undertaking in this regard shall be up-loaded by the intending bidders: **“the physical EMD shall be deposited by me / us with the Authority inviting the tender, in case I / we become the lowest tenderer, within a week of the opening of financial bid, otherwise, department may reject the tender and also take action to debar me / us from tendering in any form in IIT Delhi”**
21. **Copy of enlistment order and certificate of work experience and other documents as specified in the Press Notice / web notice shall be scanned and up-loaded to the e-Tendering website within the period of bid submission. However, certified / original copy of all the scanned and up-loaded documents as specified in press notice web / notice shall have to be submitted by the lowest bidder only along with physical EMD of the scanned copy of EMD uploaded within a week physically in the office of e-tendering authority and it shall be sole responsibility of lowest bidder.**
22. **Online bid documents submitted by intending bidders shall be opened only of those bidders, who has deposited EMD and other documents scanned and uploaded are found in order.**
23. When bids are invited in two /three stages systems and if it is desired to submit revised financial bid it shall be mandatory to submit revised financial bid. If not submitted then the bid submitted earlier shall become invalid – Not applicable.
24. **The bid submitted shall become invalid if:**
 - a. The bidder is found ineligible if he fails to upload documents from 1 to 10 on tender notice page5.
 - b. The bidder does not upload all the documents (including GST registration) as stipulated in the bid document including the undertaking about deposition of physical EMD of the scanned copy of EMD uploaded etc.
 - c. If any discrepancy is noticed between the documents as uploaded at the time of submission of bid and hard copies as submitted physically by the lowest tenderer in the office of tender opening authority.
 - d. The lowest bidder does not deposit physical EMD within a week of opening of tender.
25. Bid validity shall be 90 days from opening of financial bid.
26. Rate of bidders shall be considered inclusive of GST.

List of Documents to be scanned and uploaded within the period of bid submission:

1. Demand Draft/Pay order or Banker`s Cheque /Deposit at Call Receipt/FDR of any Scheduled Bank against EMD.
2. Enlistment order of contractor.
3. Attested certificate of work experience.
4. Certificate of Registration for GST and acknowledgement of up to date filed return of GST.
5. Affidavit as per Notice Inviting Tender Condition 1.3 page 19 of NIT.
6. Acceptance to execute INTEGRITY PACT.
7. Undertaking as per ‘Sl. No. 20’ above on firm`s letter head.

“the physical EMD shall be deposited by me / us with the Authority inviting the tender, in case I / we become the lowest tenderer, within a week of the opening of financial bid, otherwise, department may reject the tender and also take action to debar me / us from tendering in any form in IIT Delhi”

8. ESI & EPF registration.
9. FORM “F” (Duly filled with all required details).
10. Tender Fee of Rs. 1500/- in favour of IITD to be deposited in IITD Canara Bank or IITD SBI Bank & receipt copy to be scanned & uploaded in tender (technical bid) or this fees can be directly RTGS to Registrar IITD and its proof to be uploaded in technical bid

***Executive Engineer (CD-III),
For & on Behalf of BOG, IIT Delhi
HauzKhas, New Delhi-110016.***

Ch. Head:PLN-12/01

Work code- WO3490

Copy to: -

1. Executive Engineer (CD-III) for information.
2. D.A. (Works Accounts)
3. AEE (C)
4. D.R. (A/Cs) – for opening of tenders on 25/09/2020 at 11:00 AM in the office of D.R. Store
5. Notice Boards.
6. Office Copy
7. Web site Administrator, I.I.T.D
8. NIT :- Publicity on Website on Institute as well as on CPP portal <http://eprocure.gov.in> may be ensured as per instruction issued.
9. E-tendering Web. <http://eprocure.gov.in/eprocure/app> or www.iitd.ac.in

FORM "E"
STRUCTURE & ORGANISATION

1. Name & Address of the bidder
2. Telephone no./ Telex no./ Fax no.
3. Legal status of the bidder (attach copies of original document defining the legal status)
 - a. An Individual
 - b. A proprietary firm
 - c. A firm in partnership
 - d. A limited company or Corporation
4. Particulars of registration with various Government Bodies (attach attested photocopy)

Organization/ Place of registration

Registration No.

- 1.
- 2.
- 3.
5. Name and titles of Directors & Officers with designation to be concerned with this work.....!
6. Designation of individuals authorized to act for the organization.....!
7. Has the bidder or any constituent partner in case of partnership firm, ever abandoned the awarded work before its completion?
If so, give name of the project and reasons for abandonment.....!
8. Has the bidder or any constituent partner in case of partnership firm, ever been debarred/ black listed for tendering in any organization at any time? If so, give details.....!
9. Has the bidder, or any constituent partner in case of partnership firm, ever been convicted by the court of law? If so, give details.....!
10. Past work experience in IIT Delhi will be considered in deciding the Technical bid.....!

Signature of Bidder(S)

Notice Inviting Tender

INDIAN INSTITUTE OF TECHNOLOGY DELHI

HAUZ KHAS, NEW DELHI-110016

Terms & Conditions

Indian Institute of Technology Delhi is in the process of purchasing following item(s) as per details as given as under.

Details of the item	As per Tender Notice
Earnest Money Deposit to be submitted	Rs. 3,17,956/-
Warranty	As per Tender Notice, NIT & IITD form 8
Performance security	As per Tender Notice, NIT & IITD form 8

Tender Documents may be downloaded from Central Public Procurement Portal <http://eprocure.gov.in/eprocure/app>. Aspiring Bidders who have not enrolled / registered in e-procurement should enroll / register before participating through the website <http://eprocure.gov.in/eprocure/app> . The portal enrolment is free of cost. Bidders are advised to go through instructions provided at 'Instructions for online Bid Submission '.

Tenderers can access tender documents on the website (For searching in the NIC site, kindly go to Tender Search option and type 'IIT'. Thereafter, Click on "GO" button to view all IIT Delhi tenders). Select the appropriate tender and fill them with all relevant information and submit the completed tender document online on the website <http://eprocure.gov.in/eprocure/app> as per the schedule given in the next page.

No manual bids will be accepted. All quotes (both Technical and Financial should be submitted in the E-procurement portal).

Schedule

Name of Organization	Indian Institute of Technology Delhi
Tender Type (Open/Limited/EOI/Auction/Single)	Open
Tender Category (Services/Goods/works)	Works
Type/Form of Contract (Work/Supply/Auction/Service/Buy/Empanelment/ Sell)	Works
Product Category (Civil Works/Electrical Works/Fleet Management/ Computer Systems)	Civil, Electrical & Furniture Work
Source of Fund (Institute/Project)	Budget Code PLN –12/01B/WO3490
Is Multi Currency Allowed	No
Date of Issue/Publishing	15/09/2020 (17.00 Hrs)
Document Download/Sale Start Date	15/09/2020 (17.00 Hrs)
Document Download/Sale End Date	24/09/2020 (03.00 PM)
Date for Pre-Bid Conference	---
Venue of Pre-Bid Conference	---
Last Date and Time for Uploading of Bids	24/09/2020 (03.00 PM)
Date and Time of Opening of Technical Bids	25/09/2020 (03.00 PM)
Tender Fee	Rs. 1500/-
EMD	Rs. 3,17,956/- (To be paid through RTGS/NEFT. IIT Delhi Bank details are as under: Name of the Bank A/C : Registrar IIT Delhi SBI A/C No. : 10773572622 Name of the Bank : State Bank of India, IIT Delhi, HauzKhas, New Delhi-110016 IFSC Code : SBIN0001077 MICR Code : 110002156 Swift No. : SBININBB547 (This is mandatory that UTR Number is provided in the on-line quotation/bid. (Kindly refer to the UTR Column of the Declaration Sheet at Annexure-II) <u>or as per NIT/ Tender notice</u>
No. of Covers (1/2/3/4)	02
Bid Validity days (180/120/90/60/30)	90 days (From last date of opening of bids)
Address for Communication	EE(CD-III), East Campus Maintenance (Residential Area Maintenance) , IIT D.
Contact No.	011-26596237
Email Address	a26516@admin.iitd.ac.in

Instructions for Online Bid Submission:

As per the directives of Department of Expenditure, this tender document has been published on the Central Public Procurement Portal ([URL:http://eprocure.gov.in/eprocure/app](http://eprocure.gov.in/eprocure/app)). The bidders are required to submit soft copies of their bids electronically on the CPP Portal, using valid Digital Signature Certificates. The instructions given below are meant to assist the bidders in registering on the CPP Portal, prepare their bids in accordance with the requirements and submitting their bids online on the CPP Portal.

More information useful for submitting online bids on the CPP Portal may be obtained at:

<http://eprocure.gov.in/eprocure/app>

REGISTRATION

- 1) Bidders are required to enroll on the e-Procurement module of the Central Public Procurement Portal ([URL:http://eprocure.gov.in/eprocure/app](http://eprocure.gov.in/eprocure/app)) by clicking on the link “Click here to Enroll”. Enrolment on the CPP Portal is free of charge.
- 2) As part of the enrolment process, the bidders will be required to choose a unique username and assign a password for their accounts.
- 3) Bidders are advised to register their valid email address and mobile numbers as part of the registration process. These would be used for any communication from the CPP Portal.
- 4) Upon enrolment, the bidders will be required to register their valid Digital Signature Certificate (Class II or Class III Certificates with signing key usage) issued by any Certifying Authority recognized by CCA India (e.g. Sify / TCS / nCode / eMudhra etc.), with their profile.
- 5) Only one valid DSC should be registered by a bidder. Please note that the bidders are responsible to ensure that they do not lend their DSCs to others which may lead to misuse.
- 6) Bidder then logs in to the site through the secured log-in by entering their userID / password and the password of the DSC / eToken.

SEARCHING FOR TENDER DOCUMENTS

- 1) There are various search options built in the CPP Portal, to facilitate bidders to search active tenders by several parameters. These parameters could include Tender ID, organization name, location, date, value, etc. There is also an option of advanced search for tenders, wherein the bidders may combine a number of search parameters such as organization name, form of contract, location, date, other keywords etc. to search for a tender published on the CPP Portal.
- 2) Once the bidders have selected the tenders they are interested in, they may download the required documents / tender schedules. These tenders can be moved to the respective ‘My Tenders’ folder. This would enable the CPP Portal to intimate the bidders through SMS / e-mail in case there is any corrigendum issued to the tender document.
- 3) The bidder should make a note of the unique Tender ID assigned to each tender, in case they want to obtain any clarification / help from the Helpdesk.

PREPARATION OF BIDS

- 1) Bidder should take into account any corrigendum published on the tender document before submitting their bids.
- 2) Please go through the tender advertisement and the tender document carefully to understand the documents required to be submitted as part of the bid. Please note the number of covers in which the bid documents have to be submitted, the number of documents - including the names and content of each of the document that need to be submitted. Any deviations from these may lead to rejection of the bid.

- 3) Bidder, in advance, should get ready the bid documents to be submitted as indicated in the tender document / schedule and generally, they can be in PDF / XLS / RAR / DWF formats. Bid documents may be scanned with 100 dpi with black and white option.
- 4) To avoid the time and effort required in uploading the same set of standard documents which are required to be submitted as a part of every bid, a provision of uploading such standard documents (e.g. PAN card copy, annual reports, auditor certificates etc.) has been provided to the bidders. Bidders can use “My Space” area available to them to upload such documents. These documents may be directly submitted from the “My Space” area while submitting a bid, and need not be uploaded again and again. This will lead to a reduction in the time required for bid submission process.

SUBMISSION OF BIDS

- 1) Bidder should log into the site well in advance for bid submission so that he/she upload the bid in time i.e. on or before the bid submission time. Bidder will be responsible for any delay due to other issues.
- 2) The bidder has to digitally sign and upload the required bid documents one by one as indicated in the tender document.
- 3) Bidder has to select the payment option as “on-line” to pay the tender fee / EMD as applicable and enter details of the instrument. Whenever, EMD / Tender fees is sought, bidders need to pay the tender fee and EMD separately on-line through RTGS (Refer to Schedule, Page No.2).
- 4) A standard BoQ format has been provided with the tender document to be filled by all the bidders. Bidders are requested to note that they should necessarily submit their financial bids in the format provided and no other format is acceptable. Bidders are required to download the BoQ file, open it and complete the white coloured (unprotected) cells with their respective financial quotes and other details (such as name of the bidder). No other cells should be changed. Once the details have been completed, the bidder should save it and submit it online, without changing the filename. If the BoQ file is found to be modified by the bidder, the bid will be rejected.

OR

In some cases Financial Bids can be submitted in PDF format as well (in lieu of BOQ).

- 5) The server time (which is displayed on the bidders’ dashboard) will be considered as the standard time for referencing the deadlines for submission of the bids by the bidders, opening of bids etc. The bidders should follow this time during bid submission.
- 6) All the documents being submitted by the bidders would be encrypted using PKI encryption techniques to ensure the secrecy of the data. The data entered cannot be viewed by unauthorized persons until the time of bid opening. The confidentiality of the bids is maintained using the secured Socket Layer 128 bit encryption technology. Data storage encryption of sensitive fields is done.
- 7) The uploaded tender documents become readable only after the tender opening by the authorized bid openers.
- 8) Upon the successful and timely submission of bids, the portal will give a successful bid submission message & a bid summary will be displayed with the bid no. and the date & time of submission of the bid with all other relevant details.
- 9) Kindly add scanned PDF of all relevant documents in a single PDF file of compliance sheet.

ASSISTANCE TO BIDDERS

1. Any queries relating to the tender document and the terms and conditions contained therein should be addressed to the Tender Inviting Authority for a tender or the relevant contact person indicated in the tender.

2. Any queries relating to the process of online bid submission or queries relating to CPP Portal in general may be directed to the 24x7 CPP Portal Helpdesk. The contact number for the helpdesk is 1800 233 7315.

General Instructions to the Bidders

- 1) The tenders will be received online through portal <http://eprocure.gov.in/eprocure/app> . In the Technical Bids, the bidders are required to upload all the documents in .pdf format.
- 2) Possession of a Valid Class II/III Digital Signature Certificate (DSC) in the form of smart card/e-token in the company's name is a prerequisite for registration and participating in the bid submission activities through <https://eprocure.gov.in/eprocure/app> . Digital Signature Certificates can be obtained from the authorized certifying agencies, details of which are available in the web site <https://eprocure.gov.in/eprocure/app> under the link "Information about DSC".
- 3) Tenderer are advised to follow the instructions provided in the 'Instructions to the Tenderer for the e-submission of the bids online through the Central Public Procurement Portal for e Procurement at <https://eprocure.gov.in/eprocure/app>.

Terms & Conditions Details

S.No.	Specification
1.	Due date: The tender has to be submitted on-line before the due date. The offers received after the due date and time will not be considered. No manual bids will be considered.
2.	Preparation of Bids: The offer/bid should be submitted in two bid systems (i.e.) Technical bid and financial bid. The technical bid should consist of all technical details along with commercial terms and conditions. Financial bid should indicate item wise price for the items mentioned in the technical bid in the given format i.e BOQ_XXXX. OR Financial Bids to be submitted in Excel. The Technical bid and the financial bid should be submitted Online.
3.	EMD (if applicable): As per NIT
4.	Refund of EMD :- As per NIT
5.	Opening of the tender: As per Tender Notice, NIT & IITD form 8
6.	Acceptance/ Rejection of bids: The competent authority of IIT Delhi reserves the right to reject any or all offers without assigning any reason.
7.	Pre-qualification criteria: - Mentioned in Tender notice
8.	Performance Security:- Mentioned in Tender notice
9.	Force Majeure :- As per IITD form 8
10.	Risk & Cost Clause : As per IITD form 8
11.	Delivery and Documents: As per Tender Notice & NIT & IITD form 8
12.	Delayed delivery: As per Tender Notice & NIT & IITD form 8
13.	Prices: As per Tender Notice & NIT & IITD form 8
14.	Progress of Work : As per Tender Notice & NIT & IITD form 8
15.	Inspection and Tests: As per Tender Notice & NIT & IITD form 8
16.	Resolution of Disputes: As per Tender Notice & NIT & IITD form 8
17.	Applicable Law: As per Tender Notice & NIT & IITD form 8
18.	Supplier Integrity : As per Tender Notice & NIT & IITD form 8
19.	Training : As per Tender Notice & NIT & IITD form 8
20.	Installation & Demonstration : As per Tender Notice & NIT & IITD form 8
21.	Incidental services: As per Tender Notice & NIT & IITD form 8
22.	Defect liability Period : As per Tender Notice & NIT & IITD form 8
23.	Governing Language : As per Tender Notice & NIT & IITD form 8
24.	Applicable Law : As per Tender Notice & NIT & IITD form 8
25.	Notices : As per Tender Notice & NIT & IITD form 8
26.	Taxes : As per Tender Notice & NIT & IITD form 8
27.	Termination for Default : As per Tender Notice & NIT & IITD form 8
28.	Disputes and Jurisdiction: As per Tender Notice & NIT & IITD form 8
29.	Completion certificate: As per Tender Notice & NIT & IITD form 8

COMPLIANCE SHEET

TECHNICAL SPECIFICATION

S.No.	Technical Bid Requirement As per Tender Notice & NIT & IITD form 8	Compliance Y/N
1	Firm registration	
2	GST Registration	
3	GST Return	
4	ESI & EPF	
5	Experience Certificate	
6	Undertaking	
7	Affidavit	
8	INTEGRITY PACT	
9	Annexure 1	
10	Annexure 2	
11	Annexure 3	
12	EMD	
13	Tender Fee	
14	FORM "F" (Duly filled with all required details)	
15	BOQ	

I have also enclosed all relevant documents in support of my claims, (as above) in the following pages.

Signature of Bidder

Name: _____

Designation: _____

Organization Name: _____

Contact No. : _____

**<< Organization Letter Head >>
DECLARATION SHEET**

We, _____ hereby certify that all the information and data furnished by our organization with regard to this tender specification are true and complete to the best of our knowledge. I have gone through the specification, conditions and stipulations in details and agree to comply with the requirements and intent of specification.

This is certified that our organization has been registered as per Tender Notice & NIT & IITD form 8Tender. We further certified that our organization meets all the conditions of eligibility criteria laid down in this tender document.

We, further specifically certify that our organization has not been Black Listed/De Listed or put to any Holiday by any Institutional Agency/ Govt. Department/ Public Sector Undertaking in the last three years.	NAME & ADDRESS OF THE Vendor/ Manufacturer / Agent
1 Phone	As per Tender Notice & NIT
2 Fax	
3 E-mail	
4 Contact Person Name	
5 Mobile Number	
6 TIN Number	
7 PAN Number	
(In case of on-line payment of Tender Fees)	
8UTR No. (For Tender Fee)	
(In case of on-line payment of EMD)	
9 UTR No. (For EMD)	

(Signature of the Tenderer)

Name:

Seal of the Company

Bid Submission**Online Bid Submission:**

The Online bids (complete in all respect) must be uploaded online in two Envelops as explained below:-

Bid Document – 1 (Following documents to be provided as single PDF file)			
Sl. No.	Documents	Content	File Types
1.	Technical Bid	Compliance Sheet as per Annexure – I	.PDF
2.		Organization Declaration Sheet as per Annexure – II	.PDF
3.		List of organizations/ clients where the same products have been supplied (in last two years) along with their contact number(s). (Annexure-III)	.PDF
4.		Technical supporting documents in support of all claims made at Annexure-I (Annexure-IV)	.PDF
Bid Document – 2			
Sl. No.	TYPES	Content	
1.	Financial Bid	Price bid should be submitted in Excel format.	.xlsx

IITD-6 FOR e-TENDERING AND TERM & CONDITIONS

Item rate tenders are invited on behalf of Board of Governors from contractors/firms engaged in the field of civil construction work in appropriate category for the **work As per tender notice**.

1. The enlistment of the contractors should be valid on the last date of submission of tenders. In case the last date of submission of tender is extended, the enlistment of contractor should be valid on the original date of submission of tenders.
- 1.1 The work is estimated to cost **as per tender notice** This estimate, however, is given merely as a rough guide.
- 1.2 Details of criteria for eligibility As Indicated in “INFORMATION AND INSTRUCTIONS FOR CONTRACTORS FOR e-TENDERING FORMING PART OF NIT AND TO BE POSTED ON WEBSITE”
- 1.3 To become eligible for issue of tender, the tenderer shall have to furnish an affidavit as under:-

I/We undertake and confirm that eligible similar works(s) has/have not been got executed through another contractor on back to back basis. Further that, if such a violation comes to the notice of Department, then I/we shall be debarred for tendering in IITD in future forever. Also, if such a violation comes to the notice of Department before date of start of work, the Engineer-in-Charge shall be free to forfeit the entire amount of Earnest Money Deposit/Performance Guarantee. (Scanned copy to be uploaded at the time of submission of bid)
2. Agreement shall be drawn with the successful bidders on prescribed Form No. IITD - 8 (or other Standard Form as mentioned) which is available as a Govt. of India Publication. Bidders shall quote his rates as per various terms and conditions of the said form which will form part of the agreement.
3. The time allowed for carrying out the work will be **as per tender notice** from the date of start as defined in schedule ‘F’ or from the first date of handing over of the site, whichever is later, in accordance with the phasing, if any, indicated in the tender documents.
4. The site for the work shall be made available in parts as and when site will be available.
5. The bid document consisting of plans, specifications, the schedule of quantities of various types of items to be executed and the set of terms and conditions of the contract to be complied with and other necessary documents except Standard General Conditions of Contract Form can be seen from the web Site <http://eprocure.gov.in/eprocure/app> or iitd.ac.in or e-procure.gov **free** of cost.
6. After submission of the bid the contractor can re-submit revised bid any number of times but before last time and date of submission of tender as notified.
7. While submitting the revised bid, contractor can revise the rate of one or more item(s) any number of times (he need not re-enter rate of all the items) but before last time and date of submission of tender as notified.
8. If it is desired to submit revised financial bid then it shall be mandatory to submit revised financial bid. If not submitted then the tender submitted earlier shall become invalid.
9. Earnest Money in the form of Demand Draft or Pay order or Banker`s Cheque or Deposit at Call Receipt (drawn in favour of Registrar IIT Delhi, Hauz Khas, New Delhi) as specified of any Scheduled/ Nationalized Bank and shall be scanned & uploaded to the e-tendering website within the period of tender submission or through RTGS/ NEFT with UTR details and original should be deposited by lowest bidder within a week after the opening of financial bid in office of **Executive Engineer (CD-III), IIT Delhi, Hauz Khas, New Delhi**

A part of earnest money is acceptable in the form of bank guarantee also. In such case, 50% of earnest money or Rs. 20 lakh, whichever is less, will have to be deposited in shape prescribed above, and balance in shape of Bank Guarantee of any scheduled bank which is to be scanned and uploaded by the intending bidders.

Interested contractor who wish to participate in the bid has also to make following payments in the form of Demand Draft/Pay order or Banker`s Cheque of any Scheduled Bank and to be scanned and uploaded to the e-Tendering website within the period of bid submission:

(i) <http://eprocure.gov.in/eprocure/app>.

10. The bid submitted shall become invalid if:
- (i) The bidders are found not eligible.
 - (ii) The bidders do not upload all the documents (including GST registration/ **other documents as per Tender Notice**) as stipulated in the bid document.
 - (iii) If any discrepancy is noticed between the documents as uploaded at the time of submission of bid and hard copies as submitted physically in the office of tender opening authority.
 - (iv) The lowest bidder does not deposit physical EMD within a week of opening of tender.
11. The time & date of submission & opening of financial bid of contractors qualifying the **criteria as per Tender Notice** shall be communicated to them at a later date.
12. The contractor whose bid is accepted, will be required to furnish performance guarantee of 5% (Five Percent) of the tendered and accepted of the bided amount within the period specified in Schedule F. This guarantee shall be in the form of cash (in case guarantee amount is less than Rs. 10000/-) or Deposit at Call receipt of any scheduled bank/Banker's cheque of any scheduled bank/ Demand Draft of any scheduled bank/Pay order of any Scheduled Bank of any scheduled bank (in case guarantee amount is less than Rs. 1,00,000/-) or Government Securities or Fixed Deposit Receipts or irrevocable Bank Guarantee Bonds of any Scheduled Bank or the State Bank of India in accordance with the prescribed form. In case the contractor fails to deposit the said performance guarantee within the period as indicated in Schedule 'F' including the extended period if any, the Earnest Money deposited by the contractor shall be forfeited automatically without any notice to the contractor.
13. Intending Bidders are advised to inspect and examine the site and its surroundings and satisfy themselves before submitting their tenders as to the nature of the ground and sub-soil (so far as is practicable), the form and nature of the site, the means of access to the site, the accommodation they may require and in general shall themselves obtain all necessary information as to risks, contingencies and other circumstances which may influence or affect their tender. A tenderer shall be deemed to have full knowledge of the site whether he inspects it or not and no extra charge consequent on any misunderstanding or otherwise shall be allowed. The tenderer shall be responsible for arranging and maintaining at his own cost all materials, tools & plants, water, electricity access, facilities for workers and all other services required for executing the work unless otherwise specifically provided for in the contract documents. Submission of a tender by a tenderer implies that he has read this notice and all other contract documents and has made himself aware of the scope and specifications of the work to be done and of conditions and rates at which stores, tools and plant, etc. will be issued to him by the Government and local conditions and other factors having a bearing on the execution of the work.
14. The competent authority on behalf of the Board of Governors does not bind itself to accept the lowest or any other tender and reserves to itself the authority to reject any or all the tenders received without the assignment of any reason. All tenders in which any of the prescribed condition is not fulfilled or any condition including that of conditional rebate is put forth by the tenderer shall be summarily rejected.
15. Canvassing whether directly or indirectly, in connection with tenderers is strictly prohibited and the tenders submitted by the contractors who resort to canvassing will be liable to rejection.
16. The competent authority on behalf of Board of Governors reserves to himself the right of accepting the whole or any part of the tender and the tenderer shall be bound to perform the same at the rate quoted.
17. The contractor shall not be permitted to tender for works in the IITD responsible for award and execution of contracts, in which his near relative is posted a Divisional Accountant or as an officer in any capacity between the grades of Superintending Engineer and Junior Engineer (both inclusive). He shall also intimate the names of persons who are working with him in any capacity or are subsequently employed by him and who are near relatives to any gazetted officer in the Central Public Works Department or in the Ministry of Urban Development. Any breach of this condition by the contractor would render him liable to be removed from the approved list of contractors of this Department.
18. No Engineer of gazetted rank or other Gazetted Officer employed in Engineering or Administrative duties in an Engineering Department of the Government of India is allowed to work as a contractor for a period of one year after his retirement from Government service, without the previous permission of the Government of India in writing. This contract is liable to be cancelled if either the contractor or any of his employees is found any time to be such a person who had not obtained the permission of the Government of India as afore said before submission of the tender or engagement in the contractor's service.

19. The tender for the works shall remain open for acceptance for a period of ninety (90) days from the date of opening of tenders, if any tenderer withdraws his tender before the said period or issue of letter of acceptance, whichever is earlier, or makes any modifications in the terms and conditions of the tender which are not acceptable to the department, then the Government shall, without prejudice to any other right or remedy, be at liberty to forfeit 50% of the said earnest money as aforesaid. Further the tenderer shall not be allowed to participate in the retendering process of the work.
20. This notice inviting Tender shall form a part of the contract document. The successful tenderer / contractor, on acceptance of his tender by the Accepting Authority shall within 15 days from the stipulated date of start of the work, sign the contract consisting of:-
- a) The Notice Inviting Tender, all the documents including additional conditions, specifications and drawings, if any, forming part of the tender as uploaded at the time of invitation of tender and the rates quoted online at the time of submission of bid and acceptance thereof together with any correspondence leading thereto.
 - b) Standard IITD Form - 8 or other Standard IITD Form as mentioned.
21. In case any discrepancy is noticed between the documents as uploaded at the time of submission of the bid online and hard copies as submitted physically in the office of Executive Engineer, then the bid submitted shall become invalid.

Executive Engineer (CD-III)
IIT Delhi, HauzKhas,
New Delhi - 110016

Notice Inviting Tender



INDIAN INSTITUTE OF TECHNOLOGY DELHI
HAUZ KHAS, NEW DELHI
(Works Department)

**INDIAN INSTITUTE OF TECHNOLOGY
HAUZ KHAS, NEW DELHI - 110016**

NOTICE INVITING TENDER

Item rate tenders are invited on behalf of The Board of Governors, I.I.T. Delhi, Hauz Khas, New Delhi - 16 from approved and eligible contractors of **CPWD** and those of appropriate class of **M.E.S., BSNL and Railway** dealing with building and roads for the work of “**Renovation and modification of seminar hall in academic area at IIT Delhi**” **Sub Head :- Civil, Electrical & Furniture work.**

The enlistment of the contractors should be valid on the last date of submission of tenders.

In case only the last date of submission of tender is extended, the enlistment of contractor should be valid on the original date of submission of tenders.

1.1 The work is estimated to cost **Rs. 1,58,97,785/-**This estimate, however, is given merely as a rough guide.

1.1.1 The authority competent to approve NIT for the combined cost and belonging to the major discipline will consolidate NITs for calling the bids. He will also nominate Division which will deal with all matters relating to the invitation of bids.

For composite bid, besides indicating the combined estimated cost put to tender, should clearly indicates the estimated cost of each component separately. The eligibility of bidders will correspond to the combined estimated cost of different components put to bid.

1.2 Intending bidder is eligible to submit the bid provided he has definite proof from the appropriate authority, which shall be to the satisfaction of the competent authority, of having satisfactorily completed similar works of magnitude specified below:-

Criteria of eligibility for submission of bid documents.

1.2.1 Criteria of eligibility for CPWD as well as non-CPWD contractors.

Three similar works each of value not less than 40% of estimated cost or two similar work each of value not less than 60% of estimated cost or one similar work of value not less than 80% of estimated cost (rounded to nearest Rs. 1000/-) in last 7 years ending last day of the month previous to the one in which the tenders are invited.

The value of executed works shall be brought to current costing level by enhancing the actual value of work at simple rate of 7% per annum, calculated from the date of completion to the last date of receipt of application for tender.

I.I.T.D – 6 FOR e-TENDERING	I.I.T.D
------------------------------------	----------------

1.2.2 To become eligible for issue of bid, the bidders shall have to furnish an affidavit as under :-

I/We undertake and confirm that eligible similar works(s) has/have not been got executed through another contractor on back to back basis. Further that, if such a violation comes to the notice of Department, then I/we shall be debarred for bidding in I.I.T.D in future forever. Also, if such a violation comes to the notice of Department before date of start of work, the Engineer-in-Charge shall be free to forfeit the entire amount of Earnest Money Deposit/Performance Guarantee (Scanned copy to be uploaded at the time of submission of bid)

2. Agreement shall be drawn with the successful bidders on prescribed Form No. I.I.T.D 7/8 which is available as I.I.T.D. Publication. Bidders shall quote their rates as per various terms and conditions of the said form which will form part of the agreement.
3. The time allowed for carrying out the work will be **as per Tender Notice** from the date of start as defined in schedule 'F' or from the first date of handing over of the site, whichever is later, in accordance with the phasing, if any, indicated in the bid documents.
4. The site for the work shall be made available in parts as and when site will be available.
5. The bid document consisting of plans, specifications, the schedule of quantities of various types of items to be executed and the set of terms and conditions of the contract to be complied with and other necessary documents except Standard General Conditions of Contract Form can be seen from the web Site **www.iitd.ac.in or e-procure.gov.in free of cost.**
6. After submission of the bid the contractor can re-submit revised bid any number of times but before last time and date of submission of tender as notified.
7. While submitting the revised bid, contractor can revise the rate of one or more item(s) any number of times (he need not re-enter rate of all the items) but before last time and date of submission of tender as notified.
8. If it is desired to submit revised financial bid then it shall be mandatory to submit revised financial bid. If not submitted then the tender submitted earlier shall become invalid.

Copy of Enlistment Order and certificate of work experience and other documents as specified in the press notice / web notice shall be scanned and uploaded to the tender website within the period of bid submission. However, certified copy of all the scanned and uploaded documents as specified in press notice / web notice shall have to be submitted by the lowest bidder in the office of tendering authority.

Online bid documents submitted by intending bidders shall be opened only of those bidders, who has deposited tender online fees with and earnest money deposit and other documents scanned and uploaded are found in order.

The bid submitted shall become invalid & Tender fees shall not be refunded if:

- (i) The bidder is found ineligible.
- (ii) The bidder does not upload all the documents (GSTIN Registration) as stipulated in the bid document.
- (iii) If any discrepancy is noticed between the documents as uploaded at the time of submission of bid and hard copies as submitted physically by the lowest tenderer in the office of tender opening authority.

9. The contractor whose bid is accepted will be required to furnish **performance guarantee of 5% (Five Percent)** of the bid amount within the period specified in Schedule F. This guarantee shall be in the form of cash (in case guarantee amount is less than Rs. 10000/-) or Deposit at Call receipt of any scheduled bank/Banker's cheque of any scheduled bank/ Demand Draft of any scheduled bank/Pay order of any Scheduled Bank (in case guarantee amount is less than Rs.1,00,000/-) or Government Securities or Fixed

Deposit Receipts or irrevocable Bank Guarantee Bonds of any Scheduled Bank or the State Bank of India in accordance with the prescribed form. In case the contractor fails to deposit the said performance guarantee within the period as indicated in Schedule 'F' including the extended period if any, the Earnest Money deposited by the contractor shall be forfeited automatically without any notice to the contractor.

10. Intending Bidders are advised to inspect and examine the site and its surroundings and satisfy themselves before submitting their bids as to the nature of the ground and subsoil (so far as is practicable), the form and nature of the site, the means of access to the site, the accommodation they may require and in general shall themselves obtain all necessary information as to risks, contingencies and other circumstances which may influence or affect their bid. A bidder shall be deemed to have full knowledge of the site whether he inspects it or not and no extra charge consequent on any misunderstanding or otherwise shall be allowed. The bidders shall be responsible for arranging and maintaining at his own cost all materials, tools & plants, water, electricity access, facilities for workers and all other services required for executing the work unless otherwise specifically provided for in the contract documents. Submission of a bid by a bidder implies that he has read this notice and all other contract documents and has made himself aware of the scope and specifications of the work to be done and of conditions and rates at which stores, tools and plant, etc. will be issued to him by the Government and local conditions and other factors having a bearing on the execution of the work.
11. The competent authority on behalf of the Board of Governors does not bind itself to accept the lowest or any other bid and reserves to itself the authority to reject any or all the bids received without the assignment of any reason. All bids in which any of the prescribed condition is not fulfilled or any condition including that of conditional rebate is put forth by the bidder shall be summarily rejected.
12. Canvassing whether directly or indirectly, in connection with bidders is strictly prohibited and the bids submitted by the contractors who resort to canvassing will be liable to rejection.
13. The competent authority on behalf of Board of Governors reserves to himself the right of accepting the whole or any part of the bid and the bidder shall be bound to perform the same at the rate quoted.
14. The contractor shall not be permitted to bid for works in the IITD responsible for award and execution of contracts, in which his near relative is posted a Divisional Accountant or as an officer in any capacity between the grades of Superintending Engineer and Junior Engineer (both inclusive). He shall also intimate the names of persons who are working with him in any capacity or are subsequently employed by him and who are near relatives to any gazetted officer in the IIT Delhi. Any breach of this condition by the contractor would render him liable to be debarred from bidding process in future in IIT Delhi.
15. No Engineer of gazetted rank or other Gazetted Officer employed in Engineering or Administrative duties in an Engineering Department of the Government of India is allowed to work as a contractor for a period of one year after his retirement from Government service, without the prior permission of the Government of India in writing. This contract is liable to be cancelled if either the contractor or any of his employees is found any time to be such a person who had not obtained the permission of the Government of India as aforesaid before submission of the bid or engagement in the contractor's service.
16. The bid for the works shall remain open for acceptance for a period of **ninety (90) days** from the date of opening of financial bids, if any bidder withdraws his bid before the said period or issue of letter of acceptance, whichever is earlier, or makes any modifications in the terms and conditions of the bid which are not acceptable to the department, then the IIT Delhi shall, without prejudice to any other right or remedy, be at liberty to forfeit 50% of the said earnest money as aforesaid. Further the bidder shall not be allowed to participate in the re-bidding process of the work.
17. This notice inviting bid shall form a part of the contract document. The successful bidder / contractor, on acceptance of his bid by the Accepting Authority shall within 15 days from the stipulated date of start of the work, sign the contract consisting of:-

I.I.T.D – 6 FOR e-TENDERING**I.I.T.D**

- a) The Notice Inviting Bid, all the documents including additional conditions, specifications and drawings, if any, forming part of the bid as uploaded at the time of invitation of bid and the rates quoted online at the time of submission of bid and acceptance thereof together with any correspondence leading thereto.
- b) Standard IITD Form –7/8 or other Standard IITD Form as mentioned.

18.In case any discrepancy is noticed between the documents as uploaded at the time of submission of the bid online and hard copies as submitted physically in the office of Executive Engineer, then the bid submitted shall become invalid and the IIT Delhi shall without prejudice to any other right or remedy, be at liberty to forfeit 50% of the said earnest money as aforesaid. Further the bidder shall not be allowed to participate in there-bidding process of the work.

INTEGRITY PACT e-TENDERING	I.I.T.D
-----------------------------------	----------------

To,

.....,

.....,

.....

Subject:- NIT No. /IITD/EE(CD-III)/2020-2021 for the work of “Renovation and modification of Seminar Hall in academic area at IIT Delhi.”

Sub Head: - Civil, Electrical & Furniture Work

Dear Sir,

It is here by declared that I.I.T.D is committed to follow the principle of transparency, equity and competitiveness in public procurement.

The subject Notice Inviting Tender (NIT) is an invitation to offer made on the condition that the Bidder will sign the integrity Agreement, which is an integral part of tender/bid documents, failing which the tenderer / bidder will stand disqualified from the tendering process and the bid of the bidder would be summarily rejected.

This declaration shall form part and parcel of the Integrity Agreement and signing of the same shall be deemed as acceptance and signing of the Integrity Agreement on behalf of the I.I.T.D.

Yours faithfully

Executive Engineer (CD-III)

Acceptance to execute integrity pact	I.I.T.D
---	----------------

(To be signed by bidder and upload the scanned copy)

To,
Executive Engineer (CD-III),
 IIT Delhi, Hauz Khas,
 New Delhi – 110016.

Subject: Submission of Bid for the work of “Renovation and modification of Seminar Hall in academic area at IIT Delhi.”

Sub Head: - Civil, Electrical & Furniture Work

Dear Sir,

I/We acknowledge that I.I.T.D is committed to follow the principles thereof as enumerated in the Integrity Agreement enclosed with the tender/bid document.

I/We agree that the Notice Inviting Tender (NIT) is an invitation to offer made on the condition that I/We will sign the enclosed integrity Agreement, which is an integral part of tender / bid documents, failing which I/We will stand disqualified from the tendering process. I/We acknowledge that **THE MAKING OF THE BID SHALL BE REGARDED AS AN UNCONDITIONAL AND ABSOLUTE ACCEPTANCE** of this condition of the NIT.

I/We confirm acceptance and compliance with the Integrity Agreement in letter and spirit and further agree that execution of the said Integrity Agreement shall be separate and distinct from the main contract, which will come into existence when tender/bid is finally accepted by I.I.T.D. I/We acknowledge and accept the duration of the Integrity Agreement, which shall be in the line with Article 1 of the enclosed Integrity Agreement.

I/We acknowledge that in the event of my/our failure to sign and accept the Integrity Agreement, while submitting the tender/bid, I.I.T.D shall have unqualified, absolute and unfettered right to disqualify the tender / bidder and reject the tender/bid in accordance with terms and conditions of the tender/bid.

Yours faithfully

(Duly authorized signatory of the Bidder)

INTEGRITY PACT e-TENDERING

I.I.T.D

To be signed by the bidder and same signatory competent / authorized to sign the relevant contract on behalf of I.I.T.D.

INTEGRITY AGREEMENT

This Integrity Agreement is made at on this day of..... 20.....

BETWEEN

The Board of Governors, I.I.T. Delhi, Hauz Khas, New Delhi - 16 represented through Executive Engineer (CD-III) IIT Delhi.

....., (Hereinafter referred as the(Address of Division) ‘**Principal/Owner**’, which expression shall unless repugnant to the meaning or context hereof include its successors and permitted assigns)

AND

.....
(Name and Address of the Individual/firm/Company) through (Hereinafter referred to as the(Details of duly authorized signatory) ‘**Bidder/Contractor**’ and which expression shall unless repugnant to the meaning or context hereof include its successors and permitted assigns)

Preamble

WHEREAS the Principal / Owner has floated the Tender (NIT No.) (Hereinafter referred to as ‘**Tender/Bid**’) and intends to award, under laid down organizational procedure, contract for
(Name of work)hereinafter referred to as the ‘**Contract**’.

AND WHEREAS the Principal/Owner values full compliance with all relevant laws of the land, rules, regulations, economic use of resources and of fairness/transparency in its relation with its Bidder(s) and Contractor(s).AND WHEREAS to meet the purpose aforesaid both the parties have agreed to enter into this Integrity Agreement (hereinafter referred to as ‘**Integrity Pact**’ or ‘**Pact**’), the terms and conditions of which shall also be read as integral part and parcel of the Tender/Bid documents and Contract between the parties.

INTEGRATY PACT e-TENDERING	I.I.T.D
-----------------------------------	----------------

NOW, THEREFORE, in consideration of mutual covenants contained in this Pact, the parties hereby agree as follows and this Pact witnesses as under:

Article 1: Commitment of the Principal/Owner

- 1) The Principal/Owner commits itself to take all measures necessary to prevent corruption and to observe the following principles:
 - (a) No employee of the Principal/Owner, personally or through any of his/her family members, will in connection with the Tender, or the execution of the Contract, demand, take a promise for or accept, for self or third person, any material or immaterial benefit which the person is not legally entitled to.
 - (b) The Principal/Owner will, during the Tender process, treat all Bidder(s) with equity and reason. The Principal/Owner will, in particular, before and during the Tender process, provide to all Bidder(s) the same information and will not provide to any Bidder(s) confidential / additional information through which the Bidder(s) could obtain an advantage in relation to the Tender process or the Contract execution.
 - (c) The Principal/Owner shall endeavour to exclude from the Tender process any person, whose conduct in the past has been of biased nature.
- 2) If the Principal/Owner obtains information on the conduct of any of its employees which is a criminal offence under the Indian Penal code (IPC)/Prevention of Corruption Act, 1988 (PC Act) or is in violation of the principles herein mentioned or if there be a substantive suspicion in this regard, the Principal/Owner will inform the Chief Vigilance Officer and in addition can also initiate disciplinary actions as per its internal laid down policies and procedures.

Article 2: Commitment of the Bidder(s)/Contractor(s)

- 1) It is required that each Bidder/Contractor (including their respective officers, employees and agents) adhere to the highest ethical standards, and report to the Government / Department all suspected acts of **fraud or corruption or Coercion or Collusion** of which it has knowledge or becomes aware, during the tendering process and throughout the negotiation or award of a contract.
- 2) The Bidder(s)/Contractor(s) commits himself to take all measures necessary to prevent corruption. He commits himself to observe the following principles during his participation in the Tender process and during the Contract execution:
 - a) The Bidder(s)/Contractor(s) will not, directly or through any other person or firm, offer, promise or give to any of the Principal/Owner's employees involved in the Tender process or execution of the Contract or to any third person any material or other benefit which he/she is not legally entitled to, in order to obtain in exchange any advantage of any kind whatsoever during the Tender process or during the execution of the Contract.
 - b) The Bidder(s)/Contractor(s) will not enter with other Bidder(s) into any undisclosed agreement or understanding, whether formal or informal. This applies in particular to prices, specifications, certifications, subsidiary contracts, submission or non-submission of bids or any other actions to restrict competitiveness or to cartelize in the bidding process.
 - c) The Bidder(s)/Contractor(s) will not commit any offence under the relevant IPC/PC Act. Further the Bidder(s)/Contractor(s) will not use improperly, (for the purpose of competition or personal gain), or pass on to others, any information or documents provided by the Principal/Owner as part of the

business relationship, regarding plans, technical proposals and business details, including information contained or transmitted electronically.

- d) The Bidder(s)/Contractor(s) of foreign origin shall disclose the names and addresses of agents/representatives in India, if any. Similarly Bidder(s)/Contractor(s) of Indian Nationality shall disclose names and addresses of foreign agents/representatives, if any. Either the Indian agent on behalf of the foreign principal or the foreign principal directly could bid in a tender but not both. Further, in cases where an agent participate in a tender on behalf of one manufacturer, he shall not be allowed to quote on behalf of another manufacturer along with the first manufacturer in a subsequent/parallel tender for the same item.
 - e) The Bidder(s)/Contractor(s) will, when presenting his bid, disclose any and all payments he has made, is committed to or intends to make to agents, brokers or any other intermediaries in connection with the award of the Contract.
- 3) The Bidder(s)/Contractor(s) will not instigate third persons to commit offences outlined above or be an accessory to such offences.
 - 4) The Bidder(s)/Contractor(s) will not, directly or through any other person or firm indulge in fraudulent practice **means a willful misrepresentation or omission of facts or submission of fake/forged documents in order to induce public official to act in reliance thereof, with the purpose of obtaining unjust advantage by or causing damage to justified interest of others and/or to influence the procurement process to the detriment of the Government interests.**
 - 5) The Bidder(s)/Contractor(s) will not, directly or through any other person or firm use Coercive Practices (means the act of obtaining something, compelling an action or influencing a decision through intimidation, threat or the use of force directly or indirectly, where potential or actual injury may befall upon a person, his/ her reputation or property to influence their participation in the tendering process).

Article 3: Consequences of Breach

Without prejudice to any rights that may be available to the Principal/Owner under law or the Contract or its established policies and laid down procedures, the Principal/Owner shall have the following rights in case of breach of this Integrity Pact by the Bidder(s)/Contractor(s) and the Bidder/ Contractor accepts and undertakes to respect and uphold the Principal/Owner's absolute right:

- 1) If the Bidder(s)/Contractor(s), either before award or during execution of Contract has committed a transgression through a violation of Article 2 above or in any other form, such as to put his reliability or credibility in question, the Principal/Owner after giving 14 days' notice to the contractor shall have powers to disqualify the Bidder(s)/Contractor(s) from the Tender process or terminate/determine the Contract, if already executed or exclude the Bidder/Contractor from future contract award processes. The imposition and duration of the exclusion will be determined by the severity of transgression and determined by the Principal/Owner. **Such exclusion may be forever or for a limited period as decided by the Principal/Owner.**
- 2) **Forfeiture of EMD/Performance Guarantee/Security Deposit:** If the Principal/Owner has disqualified the Bidder(s) from the Tender process prior to the award of the Contract or terminated/determined the Contract or has accrued the right to terminate/determine the Contract according to Article 3(1), the Principal/Owner apart from exercising any legal rights that may have accrued to the Principal/Owner, may in its considered opinion forfeit the entire amount of Earnest Money Deposit, Performance Guarantee and Security Deposit of the Bidder/Contractor.

- 3) **Criminal Liability:** If the Principal/Owner obtains knowledge of conduct of a Bidder or Contractor, or of an employee or a representative or an associate of a Bidder or Contractor which constitutes corruption within the meaning of IPC Act, or if the Principal/Owner has substantive suspicion in this regard, the Principal/Owner will inform the same to law enforcing agencies for further investigation.

Article 4: Previous Transgression

- 1) The Bidder declares that no previous transgressions occurred in the last 5 years with any other Company in any country confirming to the anticorruption approach or with Central Government or State Government or any other Central/State Public Sector Enterprises in India that could justify his exclusion from the Tender process.
- 2) If the Bidder makes incorrect statement on this subject, he can be disqualified from the Tender process or action can be taken for banning of business dealings/ holiday listing of the Bidder/Contractor as deemed fit by the Principal/ Owner.
- 3) If the Bidder/Contractor can prove that he has resorted / recouped the damage caused by him and has installed a suitable corruption prevention system, the Principal/Owner may, at its own discretion, revoke the exclusion prematurely.

Article 5: Equal Treatment of all Bidders/Contractors/Subcontractors

- 1) The Bidder(s)/Contractor(s) undertake(s) to demand from all subcontractors a commitment in conformity with this Integrity Pact. The Bidder/Contractor shall be responsible for any violation(s) of the principles laid down in this agreement/Pact by any of its Sub-contractors/sub-vendors.
- 2) The Principal/Owner will enter into Pacts on identical terms as this one with all Bidders and Contractors.
- 3) The Principal/Owner will disqualify Bidders, who do not submit, the duly signed Pact between the Principal/Owner and the bidder, along with the Tender or violate its provisions at any stage of the Tender process, from the Tender process.

Article 6- Duration of the Pact

This Pact begins when both the parties have legally signed it. It expires for the Contractor/Vendor 09 Months after the completion of work under the contract or till the continuation of defect liability period, whichever is more and for all other bidders, till the Contract has been awarded.

If any claim is made/lodged during the time, the same shall be binding and continue to be valid despite the lapse of this Pacts as specified above, unless it is discharged/determined by the Competent Authority, I.I.T.D.

Article 7- Other Provisions

- 1) This Pact is subject to Indian Law, place of performance and jurisdiction is the Headquarters of the Division of the Principal/Owner, who has floated the Tender.
- 2) Changes and supplements need to be made in writing. Side agreements have not been made.
- 3) If the Contractor is a partnership or a consortium, this Pact must be signed by all the partners or by one or more partner holding power of attorney signed by all partners and consortium members. In case of a Company, the Pact must be signed by a representative duly authorized by board resolution.

INTEGRITY PACT e-TENDERING	I.I.T.D
-----------------------------------	----------------

- 4) Should one or several provisions of this Pact turn out to be invalid; the remainder of this Pact remains valid. In this case, the parties will strive to come to an agreement to their original intentions.
- 5) It is agreed term and condition that any dispute or difference arising between the parties with regard to the terms of this Integrity Agreement / Pact, any action taken by the Owner/Principal in accordance with this Integrity Agreement/ Pact or interpretation thereof shall not be subject to arbitration.

Article 8- LEGAL AND PRIOR RIGHTS

All rights and remedies of the parties hereto shall be in addition to all the other legal rights and remedies belonging to such parties under the Contract and/or law and the same shall be deemed to be cumulative and not alternative to such legal rights and remedies aforesaid. For the sake of brevity, both the Parties agree that this Integrity Pact will have precedence over the Tender/Contract documents with regard any of the provisions covered under this Integrity Pact.

IN WITNESS WHEREOF the parties have signed and executed this Integrity Pact at the place and date first above mentioned in the presence of following witnesses:

.....
(For and on behalf of Principal/Owner)

.....
(For and on behalf of Bidder/Contractor)

WITNESSES:

1.
(signature, name and address)

2.
(signature, name and address)

Place:

Dated :

I.I.T.D – 7/8 e-TENDERING	I.I.T.D
----------------------------------	----------------

**INDIAN INSTITUTE OF TECHNOLOGY
HAUZ KHAS, NEW DELHI - 110016**

Percentage Rate Tender/Item Rate Tender & Contract for Works

Tender for the work of: **Name of work: - “Renovation and modification of Seminar Hall in academic area at IIT Delhi.” Sub Head: - Civil, Electrical & Furniture Work**

- (i) To be submitted by **as per tender notice** to
.....
- (ii) To be opened in presence of bidders who may be present at **as per tender notice**
in the office of **D.R. (Store)**
Issued to
Signature of officer issuing the documents
Designation
Date of Issue

TENDER

I/We have read and examined the notice inviting tender, schedule, A, B, C, D, E & F Specifications applicable, Drawings & Designs, General Rules and Directions, Conditions of Contract, clauses of contract, Special conditions, Schedule of Rate & other documents and Rules referred to in the conditions of contract and all other contents in the tender document for the work. I/We hereby tender for the execution of the work specified for the The Board of Governors, I.I.T. Delhi, HauzKhas, New Delhi - 16 within the time specified in Schedule ‘F’ viz., schedule of quantities and in accordance in all respect with the specifications, designs, drawing and instructions in writing referred to in Rule-1 of General Rules and Directions and in Clause 11 of the Conditions of contract and with such materials as are provided for, by, and in respect of accordance with, such conditions so far as applicable.

We agree to keep the tender open for ninety (90) days from the due date of its opening / ninety days from the date of opening of financial bid.

A sum of **as per tender notice** is hereby forwarded in Banker Cheque or Demand Draft or Fixed Deposit receipt of a schedule bank drawn in favour of IIT Delhi as earnest money. If I/We, fail to furnish the prescribed performance guarantee within prescribed period. I/We agree that the said The Board of Governors, I.I.T. Delhi, Hauz Khas, New Delhi - 16 or his successors, in office shall without prejudice to any other right or remedy, be at liberty to forfeit the said earnest money absolutely. Further, if I/We fail to commence work as specified, I/We agree that The Board of Governors, I.I.T. Delhi, Hauz Khas, New Delhi - 16 or the successors in office shall without prejudice to any other right or remedy available in law, be at liberty to forfeit the said earnest money and the performance guarantee absolutely, otherwise the said earnest money shall be retained by him towards security deposit to execute all the works referred to in the tender documents upon the terms and conditions contained or referred to those in excess of that limit at the rates to be determined in accordance with the provision contained in Clause 12.2 and 12.3 of the tender form. Further, I/We agree that in case of forfeiture of Earnest Money & Performance Guarantee as aforesaid. I/We shall be debarred for participation in the re-tendering process of the work.

I/We undertake and confirm that eligible similar work(s) has/have not been got executed through another contractor on back to back basis. Further that, if such a violation comes to the notice of Department, then I/We shall be debarred for tendering in I.I.T.D in future forever. Also, if such a violation comes to the notice of Department before date of start of work, the Engineer-in-Charge shall be free to forfeit the entire amount of Earnest Money Deposit/Performance Guarantee.

I/We hereby declare that I/We shall treat the tender documents drawings and other records connected with the work as secret/confidential documents and shall not communicate information/derived there from to any person other than a person to whom I/We am/are authorized to communicate the same or use the information in any manner prejudicial to the safety of the State.

Dated:

Signature of Contractor

Witness:

Postal Address

Address:

Occupation:

I.I.T.D – 7/8 e-TENDERING

I.I.T.D

ACCEPTANCE

The above tender (as modified by you as provided in the letters mentioned hereunder) is accepted by me for an on behalf of The Board of Governors, I.I.T. Delhi, Hauz Khas, New Delhi - 16 for a sum of (Rupees.....).

The letters referred to below shall form part of this contract agreement:-

- (a)
- (b)
- (c)

For & on behalf of Board of Governors, IIT Delhi

Signature

Dated: Designation

PROFORMA OF SCHEDULES	I.I.T.D
------------------------------	----------------

PROFORMA OF SCHEDULES

(Separate Performa for Civil, Elect. & Hort. Works in case of Composite Tenders) (Operative Schedules to be supplied separately to each intending tenderer)

SCHEDULE 'A'

Schedule of quantities (enclosed)

SCHEDULE 'B'

Schedule of materials to be issued to the contractor.

S.No.	Description of item	Quantity	Rates in figures & words at which the material will be charged to the Contractor	Place of issue
1			4	
	← Nil →			

SCHEDULE 'C'

Tools and plants to be hired to the contractor

S.No.	Description	Hire charges per day	Place of Issue
1			
	← Nil →		

SCHEDULE 'D'

Extra schedule for specific requirements/document for the work, if any.

----- **Nil** -----

PROFORMA OF SCHEDULES	I.I.T.D
------------------------------	----------------

SCHEDULE 'E'

Reference to General Conditions of contract.

Name of work:- "Renovation and modification of Seminar Hall in academic area at IIT Delhi." Sub Head: - Civil, Electrical & Furniture Work

Estimated cost of work	: Rs. 1,58,97,785/-
(i) Earnest Money	: Rs. 3,17,956/-
(ii) Performance Guarantee	: 5% of tendered value
(iii) Security Deposit	: 5% of tendered value

SCHEDULE 'F'**GENERAL RULES& DIRECTIONS : Officer inviting tender IITD/ Form – 7/8-2010**

Maximum percentage for quantity of items of work to be executed beyond which rates are to be determined in accordance with Clauses 12.2 & 12.3:

See below

Definitions:

2(v)	Engineer-in-Charge	Executive Engineer	
2(viii)	Accepting Authority	Institute Engineer	
2(x)	Percentage on cost of materials and Labour to cover all overheads and profits:		15%
2(xi)	Standard Schedule of Rates –	Civil & Electrical work :- DSR 2018 and Market Rate	
2(xii)	Department –	Works department at I.I.T Delhi	
9(ii)	Standard I.I.T.D Contract Form up to date of submission of tender.	GCC 2010, I.I.T.D Form 7/8-2010 modified & Corrected	

Clause 1

- | | |
|---|---------|
| (i) Time allowed for submission of Performance Guarantee from the date of issue of letter of acceptance | 15 days |
| (iii) Maximum allowable extension with late fees @ 0.1% per day of performance guarantee amount beyond the period provided in (i) above
1 to 15 days | |

Clause 2**Authority for fixing compensation under clause 2****Institute Engineer**

PROFORMA OF SCHEDULES**I.I.T.D****Clause 2A**

Whether Clause 2A shall be applicable

No**Clause 5**Number of days from the date of issue of letter
of award for reckoning date of start

10 (Ten) days

Mile stone(s) as per table given below:-

Sl. No.	Description of Milestone (Financial)	Time allowed in days (from date of start)	Amount to be with-held in case of non-achievement of mile stone
			In the event of not achieving the necessary progress as assessed from the running payment, 1% of the Tender value of work will be withheld for failure of each milestone.
1	1/8 th (of the whole work)	1/4 th (of the whole work)	
2	3/8 th (of the whole work)	1/2 th (of the whole work)	
3	3/4 th (of the whole work)	3/4 th (of the whole work)	
4	Full	Full	

Time allowed for execution of work

As per tender notice.

Authority to decide:

(i) Extension of time

Institute Engineer.

(ii) Rescheduling of mile stones

Institute Engineer.**Clause 6, 6A**Clause applicable - (6 or 6A) **Clause 6A**.....**Clause 7**Gross work to be done together with net payment /adjustment
of advances for material collected, if any, since the last such
payment for being eligible to interim payment

Rs. 25.00 Lakhs

Clause 10A

List of testing equipment to be provided by the contractor at site lab.

- 1..... 2. 3.....
 4..... 5. **Nil** 6.....

~~Clause 10B(ii)~~

Whether Clause 10 B (ii) shall be applicable **No**

Clause 10C

Component of labour expressed as percent of value of work = 25%

Clause 10CA

S.N.	Material covered under this clause	Nearest Materials (other than cement, reinforcement bars and the structural steel) for which All India Wholesale Price Index to be followed	Base Price of all Materials covered under clause 10 CA*
1			
2			
3			
4		Nil	

* Base price of all the materials covered under clause 10 CA is to be mentioned at the time of approved of NIT.

Clause 10CC :- Not applicable in this NIT/Tender

Clause 10 CC to be applicable in contracts with stipulated period of completion exceeding the period shown in next column **18 months**

Schedule of component of other Materials, Labour, POL etc. for price escalation.

Component of civil (except materials covered under clause 10CA) /Electrical construction Materials expressed as percent of total value of work. - **Xm**

Component of Labour - expressed as percent of total value of work. **Y**..... %

Component of P.O.L. - expressed as percent of total value of work. **Z**..... %

Clause 11

Specifications to be followed for execution of work

CPWD specifications 2009 Vol-1&2 with upto date correction slips & manufacturers specifications

PROFORMA OF SCHEDULES	I.I.T.D
------------------------------	----------------

Clause 12

Type of work -Maintenance works including works of up-gradation, aesthetic, special repair, addition/ alteration.

12.2. & 12.3 Deviation Limit beyond which clauses
12.2 & 12.3 shall apply for all maintenance work **50%**

Clause 16

Competent Authority for

deciding reduced rates.

Institute **Engineer**

Clause 18

List of mandatory machinery, tools & plants to be deployed by the contractor at site:-

1. 2. 3.
4.
5. 6.
7. 8.

Clause 25

Constitution of Dispute Redressal Committee (DRC)	Competent Authority to appoint DRC
DRC shall constitute one Chairman and two members	Director Nil Institute of Technology Delhi

Clause 36 (i)

Requirement of Technical Representative(s) and recovery Rate

S. No.	Minimum Qualification of Technical Representative	Discipline	Designation (Principal Technical/ Technical Representative)	Minimum Experience (Years)	Number	Rate at which recovery shall be made from the contractor in the event of not fulfilling provision of clause 36(i)	
						Figures	Words
1.	Graduate Engineer Or Diploma Engineer	Civil	Project Manager Cum Planning/ quality/Site/billing Engineer	2	1	Rs.15,000.00 per month.	Rupees Fifteen Thousand only per month
				5	1		

Assistant Engineers retired from Government services that are holding Diploma will be treated at par with Graduate Engineers.

PROFORMA OF SCHEDULES	I.I.T.D
------------------------------	----------------

Clause 42

- (i) (a) Schedule/statement for determining theoretical quantity of cement & bitumen on the basis of Delhi Schedule of Rates **2018** printed by C.P.W.D.
- (ii) Variations permissible on theoretical quantities:
- (a) Cement
- For works with estimated cost put to tender not more than Rs. 5 lakh. 3% plus/minus.
- For works with estimated cost put to tender more than Rs.5 lakh. 2% plus/minus.
- (b) Bitumen All Works 2.5% plus only & nil on minus side.
- (c) Steel Reinforcement and structural steel sections for each diameter, section and category 2% plus/minus
- (d) All other materials. Nil

RECOVERY RATES FOR QUANTITIES BEYOND PERMISSIBLE VARIATION

S. No.	Description of Item	Rates in figures and words at which recovery shall be made from the Contractor	
		Excess beyond permissible variation	Less use beyond permissible variation
1.	Cement	As per CPWD Specification 2009	
2.	Steel Reinforcement		
3.	Structural Sections		
4.	Bitumen issued free		
5.	Bitumen issued at stipulated fixed Price		

BANK GUARANTEE BOND

I.I.T.D

**Form of Earnest Money Deposit
Bank Guarantee Bond**

WHEREAS, contractor .. (Name of contractor) (hereinafter called "the contractor") has submitted his tender dated (date) for the construction of(name of work) (hereinafter called "the Tender")

KNOW ALL PEOPLE by these presents that we(name of bank) having our registered office at..... (hereinafter called "the Bank") are bound unto.....
(Name and division of Executive Engineer) (hereinafter called "the Engineer-in-Charge") in the sum of Rs. (Rs. in words) for which payment well and truly to be made to the said Engineer-in-Charge the Bank binds itself, his successors and assigns by these presents.

SEALED with the Common Seal of the said Bank thisday of 20....

THE CONDITIONS of this obligation are:

- (1) If after tender opening the Contractor withdraws, his tender during the period of validity of tender (including extended validity of tender) specified in the Form of Tender;
- (2) If the contractor having been notified of the acceptance of his tender by the Engineer-in-Charge:
 - (a) fails or refuses to execute the Form of Agreement in accordance with the Instructions to contractor, if required;
 - OR
 - (b) fails or refuses to furnish the Performance Guarantee, in accordance with the provisions of tender document and Instructions to contractor,
 - OR
 - (c) fails or refuses to start the work, in accordance with the provisions of the contract and Instructions to contractor,
 - OR
 - (d) fails or refuses to submit fresh Bank Guarantee of an equal amount of this Bank Guarantee, against Security Deposit after award of contract.

We undertake to pay to the Engineer-in-Charge either up to the above amount or part thereof upon receipt of his first written demand, without the Engineer-in-Charge having to substantiates his demand, provided that in his demand the Engineer-in-Charge will note that the amount claimed by his is due to him owing to the occurrence of one or any of the above conditions, specifying the occurred condition or conditions.

This Guarantee will remain in force up to and including the date* after the deadline for submission of tender as such deadline is stated in the Instructions to contractor or as it may be extended by the Engineer-in-Charge, notice of which extension(s) to the Bank is hereby waived. Any demand in respect of this Guarantee should reach the Bank not later than the above date.

DATE

WITNESSSEAL

SIGNATURE OF THE BANK

(SIGNATURE, NAME AND ADDRESS)

*Date to be worked out on the basis of validity period of 6 months from last date of receipt of tender.

LIST OF APPROVED MAKES FOR CIVIL & Electrical works**A-Civil Items**

S. No.	Description	Approved Makes
1	EWC Seat Covers	HINDWARE/PARRYWARE/ CERA
2	C.P Brass Fittings/ Accessories	JAQUAR, MARC, KOHLAR
3	Cement (Grey) OPC/ PPC Grade-43	ACC/ L&T/ J.K./ BIRLA/ ULTRA TECH/ VIKRAM
4	Cement (White)	J.K./ BIRLA
5	Reinforcement Steel	PRIMARY MANUFACTURERS APPROVED BY MINISTRY OF STEEL/ SECONDARY MANUFACTURER HAVING VALID BIS LICENSE (TO BE AS PER LATEST BIS PROVISIONS)
6	Structural Steel	PRIMARY MANUFACTURERS APPROVED BY MINISTRY OF STEEL/ SECONDARY MANUFACTURER HAVING VALID BIS LICENSE (TO BE AS PER LATEST BIS PROVISIONS)
7	Stainless Steel (Grade 304)	JINDAL/ SAIL/ SALEM
8	Bricks	COMMERCIALLY AVAILABLE OR REQUIRED STRENGTH
9	Aluminum Sections	HINDALCO/ JINDAL/ MAHAVIR
10	Flush Doors	CENTURY/ MERINO/ DURO BOARD/ GREEN
11	Laminates	GREENLAM/ DURO/ ARCHID/ MERINO/ DECOLAM/ CENTURY
12	Glass	SAINT GOBIN/ MODI FLOAT/ ASAHI FLOAT
13	Ceramic Glazed tiles/ Border tiles	1 ST QUALITY KAJARIA / NITCO/ JOHNSON/ ORIENT/ SOMANY
14	Vitrified Tiles	JOHNSON/ KAJARIA/ ORIENT/ SOMANY
15	Interlocking precast paver blocks/ Kerb Stone	HINDUSTAN TILES/ SWASTIK/ DALAL
16	Stainless Steel Hinges	JOLLY/ GARG/ AMIT/ ASI/ SUPREME
17	Stainless Steel Nuts bolts / Screws	KUNDAN/ PUJA/ ATUL/ GKW
18	Paint/ Primer/ Oil bound distemper/ Acrylic paint/ Plastic paint	1 ST QUALITY PAINTS OF ASIAN/ BERGER/ NEROLAC/ SHALIMAR/ DULUX
19	Water Proof Cement Paint/ Exterior Paint	1 ST QUALITY PAINTS OF ASIAN/ BERGER/ NEROLAC/ SHALIMAR/ DULUX
20	Sanitary ware (Vitreous China) (European Seats, Urinals, Wash Basins, etc.)	HINDWARE/ PARRYWARE/ CERA
21	G.I. Pipes	TATA/ JINDAL(HISSAR)/ BHUSHAN/ APL APPOLO/ TT SWASTIK
22	G.I. Fittings	UNIK/ ZOLOTO/ AM
23	Stainless Steel Sink	NEELKANTH/ JAINA/ KINGSTON (COBRA)/ PRAYAG
24	Commercial Board/ Ply	MERINO/ DURO/ GREEN/ CENTURY/ KIT (SWASTIK)
25	CI Pipes/ Fittings & Manhole covers	RIF/ NECO/ BENGAL IRON WORKS/ BC/ SKF
26	CI Pipes "Class LA"	NICO/ KESORAM/ ELECTRO STEEL/ KAPILANSH
27	Floor Spring	DOORKING/ EVERITE/ SANDHU
28	Door Closer	EVERITE/ SANDHU/ HARDWIN
29	Mirror	ATUL/ MODIGUARD/ SAINT GOBAIN/ AASHI
30	Vertical Blinds	VISTA/ MAC/ MARVEL DÉCOR/ SAINT GOBAIN
31	False Ceiling	ARMSTROBG/ SAINT GOBAIN/ META WORTH
32	Water Proofing Compound	CICO/ FOSROC/ PIDILITE/ ECMAS/ ASIAN
33	Polymer Compound	CICO/ PIDILITE/ FOSROC/ ECMAS/ ASIAN
34	Particle Board	NOVA PAN/ BHUTAN BOARD/ ECO BOARD
35	Rust Remover/ Anticorrosive	FOSROC/ CICO/ PIDILITE/ ECMAS/ ASIAN
36	Adhesive	FEVICOL/ VAMICOL/ DUNLOP/ VAM ORGANIC
37	Tile Adhesive	PIDILITE/ FERROUSCRETE/ BALLNDURA/ CICO
38	Wall Putty	BIRLA / JK/ SARA
39	Epoxy Grout	BALLENDURA/ KERAKOLL/ FERROUSCRETE
40	PVC Water storage tank (ISI marked)	SINTEC/ UNI PLAST/ POLYWELL
41	PVC insulated water storage tank Heavy duty 4/5 layer	SINTEX/ UNI PLAST/ POLYWELL/ EURO
42	Brass Ball Valve/ Gate Valve/ Float Valve	ZOLOTO/ AM/ LEADER/ SANT

43	Aluminum Door Fittings	CLASSIC/ EVEREST/ ARGENT
44	Brass Bib/ Stop Cock	AGI/ ELITE/ SHAKTI/ SANT/ LEADER/ PRIMA
45	Thermoplastic Paint	CBM/ CMS/ S.N. INDUSTRIES
46	Plaster of Paris Putty	ADHARSHREE/ SHREE RAM/ J.K./ BIRLA
47	Rcc Pipe	LAKSHMI/ SOOD & SOOD/ JAIN & CO. / DIWAN SPUN PIPES
48	Pvc Pipe	PRAKASH/ PRINCE/ SUPREME
49	Sandwich Roof Panel (Puff Panel)	JSW, BHUSHAN, D-META
50	WPC Board And MPC Board	FLORESTA, ECOSTE, RAJ SHREE
51	WPC Door Frame	FLORESTA, ECOSTE, RAJ SHREE
52	Self Closing Hinges	HETTICH, KITCH, PLUM
53	Poly Carbonate Sheet	GE LEXAN / POLYGAL/ TUFLITE
54	Acp Panel	ALSTRONG/ ALUCOBOND/ EUROBOND/ ALUDECOR
55	Acoustic Wooden/ Fabric Paneling	ARMSTRONG/ ANUTONE/CREDENCE/ TOPAKUSTIC
56	Polyvinyl Flooring	ARMSTRONG / POLY FLOR/ TARKETT
57	Glow Stud, Solar Power Stud	ROAD STAR / 3M / DARK EYE /EVERY DENNISON
58	Wooden Flooring	VISTA/ ACTION TESA/ ARMSTRONG/ PERGO
59	Sun Control Film	3M/ GARWARE/ SAINT GOBAIN
60	Insulation	UP TWIGA LTD OR EQUIVALENT
61	Fire Door	NAVAIR/ SHAKTI/ GODREJ/ RADIANT
62	Flush Door Shutters Of Various Thickness	MERINO/ DURO/ GREEN/ CENTURY/ KIT (SWASTIK)
	Furniture	
63	Work Station	GODREJ INTERIO/ HAWORTH/ STEELCASE/ WIPRO/ FEATHERLITE/ HERMAN MILLER
64	Executive Table/ Other Table	GODREJ INTERIO/ HAWORTH/ STEELCASE/ WIPRO/ FEATHERLITE/ HERMAN MILLER
65	Chair/ Audi Chair	GODREJ INTERIO/ HAWORTH/ STEELCASE/ WIPRO/ FEATHERLITE/ HERMAN MILLER
66	Lab Furniture's	KEWANEE/ WALDNER/ GODREJ/ WIPRO/ FEATHERLITE
67	Hostel Beds And Cots	ZUARI/ EVOK/ GODREJ/ WIPRO/ FEATHERLITE
68	Hospital Beds	HUNTLEY/ STRIKER/ GODREJ/ WIPRO/ FEATHERLITE
	Electrical	
69	LED Luminaire	PHILIPS/ PANASONIC/ WIPRO/ BAJAJ
70	Conduit	ISI MARKED
71	Power Cables	HAVELLS/ NICCO/ SKYTONE/ GLOSTER
72	Copper Wires	FINOLEX/ HAVELLS/ KEI/ POLYCAB
73	MCB	HAVELLS/ L&T/ SIEMENS/ STANDARD/ CROMPTON/ LEGRAND/ GM/ C&S
74	DB	HAVELLS/ L&T/ SIEMENS/ STANDARD/ CROMPTON/ LEGRAND/ GM/ C&S
75	Switch & Socket	LEGRAND/ HAVELLS CRABTREE/ L&T/ MDS/ WIPRO NORTH WEST/ GM/ POLYCAB/ SCHNEIDER
76	Ceiling Fan	USHA/ HAVELLS/ ATOMBERG/ ORIENT/ BAJAJ
77	Fan Regulator	GM/ NORTH WST/ HAVELLS/ POLYCAB/ MDS/ LEGRAND
78	Industrial Plug Sockets	HAVELLS/ STANDARD/ BCH/ L&T
79	Fresh Air/ Exhaust Fans	HAVELLS/ USHA/ BAJAJ/ ORIENT
80	MCCB	SIEMENS/ L&T/ GE POWER CONTROLS/ C&S/ CROMPTON/ HAVELLS/ LEGRAND
81	PVC (DMC) Trunking with all accessories	HAGER/ LEGRAND/ GM
82	SFU	HAVELLS/ L&T/ STANDARD/ HPL
83	VRF/ VRV AC Unit	BLUE STAR/ KIRLOSKAR/ DAIKIN/ HITACHI
84	CPVC Pipe	SUPREME/ SUDHAKAR/ FONOLEX/ PLAZA/ ALG
85	Control Cable	HAVELLS/ GLOSTER/ KEC/ NICCO/ INCAB/ UNIVERSAL/ FINOLEX/ RR KABEL/ V-GUARD/ KEI WITH ISI MARKED

INDIAN INSTITUTE OF TECHNOLOGY: NEW DELHI
HAUZ KHAS: NEW DELHI
ADDITIONAL CONDITIONS

1. Non Judicial stamp paper worth Rs. 10/- (Ten Rupees only) will be submitted by contractor which will have to be signed as token of acceptance.
2. No T & P would be supplied by the Institute and contractor will have to make his own arrangement.
3. The contractors are advised to get acquainted with the proposed work including specifications & its site and additional conditions carefully before quoting. No claim of any sort shall be entertained on account of any site conditions and ignorance of specifications & additional conditions. The work shall be carried out as per the availability of site.
4. The work shall be carried out as per CPWD specifications for civil and electrical work with up – to date correction slips unless otherwise specified in the nomenclature of individual item or in the specification, additional conditions where specifications are silent, the decision of Engineer-in-Charge shall be final and binding on contractor.
5. The rates quoted by the contractor shall be taken as net and nothing extra shall be paid on account of royalty, Cartage, GST & stacking of material required at places etc. The rates for different items of work shall apply for all Heights & Depths, Leads & Lifts unless otherwise specified in the agreement or specifications applicable in the agreement.
6. Care shall be taken by the bidder to avoid the damage to any civil work & the existing services/ service line etc. any damage caused to Civil or any of the existing services/ service lines, shall be restore to its original shape to the entire satisfaction of the Engineer-in-charge and made functional by the bidder immediately at his own failing which the same shall be got done and made functional by department at the risk and cost of the bidder.
7. Articles manufactured by the reputed firms as approved by engineer-in-charge and given in approved make list in tender only to be used at work.
8. The sample of material required in the work brought at site shall be got approved from Engineer –in-Charge before use in execution of work.
9. The sample of material required for Testing shall be provided at free of cost by the contractor. Testing charges if any shall be borne by the IITD if satisfactory report and if test results are unsatisfactory than testing charges shall be deducted from bills of contractor. All other expenditure to be incurred for taking sample, conveyance, packing etc. shall be borne by the contractor.
10. The contractor shall submit a detailed program of work within 7 days of the date of award of work. The Engineer – in-Charge can modify the program and the contractors have to work accordingly.
11. The contractor shall make his own arrangement for getting the permission with respect to movement of trucks from the Traffic Police.
12. No payment shall be made to contractor for any damage caused by the rain, snowfall or any other natural causes what so ever during the execution of work.
13. Some restrictions may be imposed by the security staff of IIT Delhi etc. on the working and or movement of labour& material. **No labour camp/ huts shall be allowed in IIT Campus. The contractor shall make his own arrangement for labour huts outside the campus.** However constructions of cement godown and Chowkidar's hut in the Campus shall be permitted. The contractor shall be bound to follow all such restrictions/ instructions and nothing shall be payable on this account.
14. The contractor shall be fully responsible for the safe custody of the material issued or brought at site by him for doing the work.

15. The building rubbish / Garbage generated at site due to construction activities shall be removed from the site immediately & shall be disposed off by the contractor to the approved dumping site of MCD and all statutory approvals from local bodies shall be a sole responsibility of contractor.
16. The contractor shall clean the site thoroughly of scaffolding materials, rubbish, equipment's left out of his work & dress the site around the building to the complete satisfaction of the Engineer-in-Charge before the work is treated as completed.
17. Contractor has to quote against the item of schedule of credit of material. The contractor cannot quote either minus rate or Zero rate for these items.
18. Income tax and other taxes as applicable shall be deducted from the bills of contractor.
19. 1% labour cess or as applicable will be deducted from the bills of contractor.
20. Water charges @1% and Electricity charges @0.50% of gross work done shall be deducted from bills of contractor if electricity and water provided by IIT Delhi.
21. Agency has to take proper safety measures during the execution of work.
22. **GCC for 7/8 shall form part of NIT and the bidder shall go through GCC- 2010 before quoting rates and the same shall be deemed to be accepted by bidder if he participates in the tender.**
23. ESI & EPF shall be reimbursed as per norms on production of original receipt of ESI & EPF from contractor specific to this work. .
24. The contractor shall submit the program of execution of work as per clause 5 of GCC of IIT form 7/8 of NIT including list of workers to be deployed by contractor for this work.
25. Contractor shall be responsible for keeping site free of any kind of mosquito breeding. If it is found that breeding is taking place the entire responsibility shall be of contractor to bear challan etc. done by local bodies.
26. Work shall be executed as per the Architectural drawings and instructions of Engineer-in-charge/ Architect or his representatives. The Architectural drawing and instruction of Engineer-in-charge/ Architect shall be strictly adhered.
27. Rate quoted by the bidders shall be inclusive of GST and nothing extra shall be paid on account of GST.
28. The Audi chair will be got fixed by the agency recommended by original manufacturer of Audi chair and approved by Engineer-in charge.
29. Original warranty certificate from O.E.M/ Original manufacturer of furniture will be obtained by the agency and same will be handed over to the representative of engineer-in-charge.
30. OEM Authorization certificates as per annexure-IV will be submitted by the contractor. Final bill only be cleared after submitting the original warranty certificate & OEM authorization certificate from the manufacturer of the furniture.
31. The seminar hall is situated at a very busy location & surrounded by offices of top administrative officer of the institute hence it is possible that work may be hindered during normal working hours in that case work will be carried out during holiday and odd hours only and nothing extra will be paid on this account.
32. Electrical work will be executed only through the agency who is having valid electrical license and the copy of valid electrical license will be submitted before start of work.
33. The name of make/ model number of Audi chair to be procured by the successful bidder shall be as per the choice of the IIT Delhi authorities. The IIT Delhi Authorities decision in this regard shall be final and binding on the contract.

Fixing Procedure & details of Audi Chair

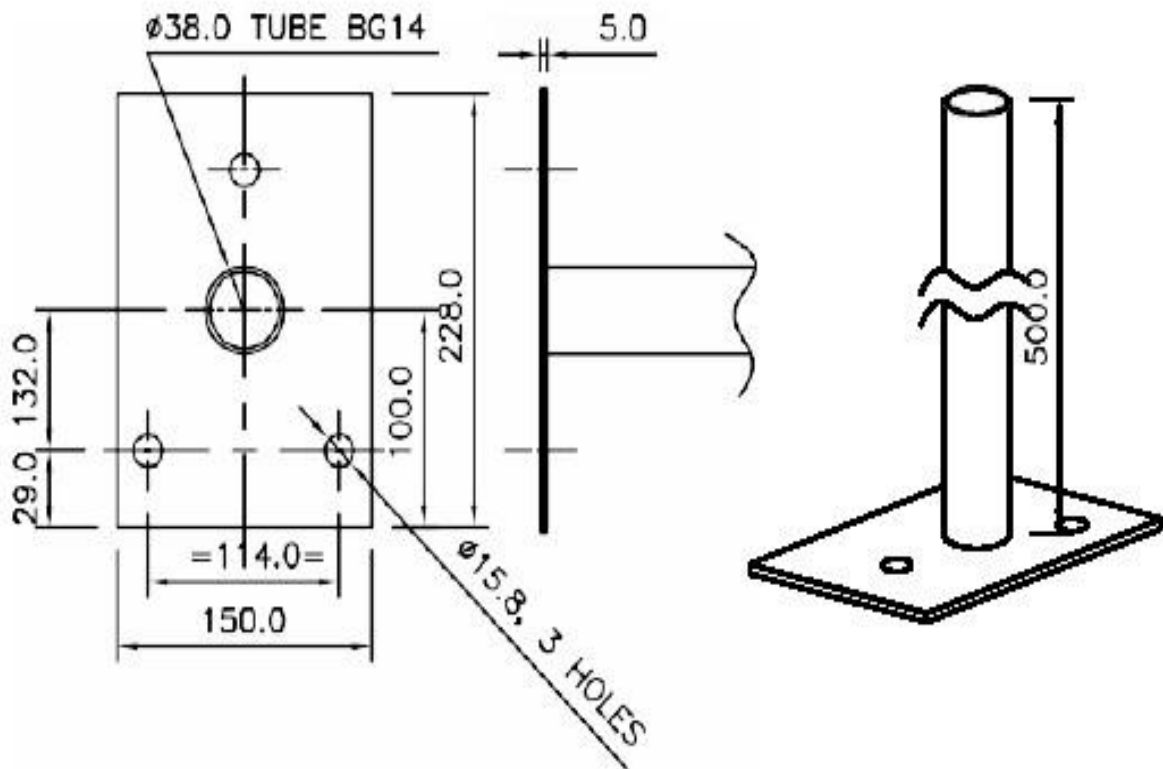

Procedures:

- Follow the standard guidelines for installation of Dummy base plate.
- Fixing the Dummy grouting plate (preferably in more than 1 location – Ideally 3) as shown above using M10 20 (83L)MM stud Anchor (anchorage length of 67 to 70 mm should go inside the main floor).
- Pull the pipe rigorously (Applying force parallel to the ground).
Note: In case of presence of a carpet, necessary portion must be removed to carry out this test.

Checks:

- The drilled holes should come out very neat, without any chipping or breaking of edges.
- The compactness of the floor (along the thickness) should be uniform.
- There should not be any crack between 2 adjacent holes of the same base plate (due to vibration or while drilling or when the pin is hammered for driving the foundation expansion bolt).
- There should not be any obstruction to drilling because of steel bars or wire mesh embedded in concrete.
- Wherever possible it should be checked whether crack has appeared on the underside of the slab esp. 1st floor upwards.
- After pulling the pipe rigorously, The Plate should not come out or bolt should not loosen out.

ANNEXURE-IV

To,
The Executive Engineer (CD-III)
Indian Institute of Technology, Delhi
Hauz Khas, New Delhi-110016

**Name of Work – Renovation and Modification of Seminar Hall in academic area at IIT Delhi.
Sub Head – Civil, Electrical and Furniture work**

Subject- OEM/ Original manufacture Of Audi chair authorization certificate- for Audi chair as per BOQ

Dear Sir,
This is to inform you that M/s. (OEM/ Original manufacturer of Audi chair name) having its. Regd. Office at Authorizes M/s.(Company name), having its Regd. Office at is hereby authorized to supply, install, test and commission our audi chair against your above mentioned tender. We shall provide full support to M/s.(company name) for our range of products quoted by them to meet the above mentioned tender requirements. We shall provide 2 years standard warranty at no extra cost.

The undersigned is authorized to issue such authorization on behalf of M/s.(OEM name)

For _____

Authorized Signatory (OEM)

IITD -2010 CORRECTION SLIPS
In general condition of contract for IIT Delhi works department 2010

	Existing	Modified
Reference	Existing Provision	Modified Provision
Clause 3 (vii)	If the contractor shall obtain a contract with Government as a result of wrong tendering or other non-bonafide methods of competitive tendering.	If the contractor had secured the contract with Government as a result of wrong tendering or other non-bonafide methods of competitive tendering or commits breach of Integrity Agreement.
Reference	Existing Provision	Modified Provision
<u>Deviations /variation extent and pricing</u>	<p><u>CLAUSE 12</u> The Engineer-in-Charge shall have power (i) to make alteration in, omissions from, additions to, or substitutions for the original specifications, drawings, designs and instructions that may appear to him to be necessary or advisable during the progress of the work, and (ii) to omit a part of the works in case of non-availability of a portion of the site or for any other reasons and the contractor shall be bound to carry out the works in accordance with any instructions given to him writing signed by the Engineer-in-Charge and such alterations, omissions, additions or substitutions shall form part of the contract as if originally provided therein and any altered, additional or substituted work which the contractor may be directed to do in the manner specified above as part of the works, shall be carried out by the contractor on the same conditions in all respects including price on which he agreed to do the main works except as hereafter provided.</p>	<p><u>CLAUSE 12</u> The Engineer-in-Charge shall have power (i) to make alteration in, omissions from, additions to, or substitutions for the original specifications, drawings, designs and instructions that may appear to him to be necessary or advisable during the progress of the work, and (ii) to omit a part of the works in case of non-availability of a portion of the site or for any other reasons and the contractor shall be bound to carry out the works in accordance with any instructions given to him writing signed by the Engineer-in-Charge and such alterations, omissions, additions or substitutions shall form part of the contract as if originally provided therein and any altered, additional or substituted work which the contractor may be directed to do in the manner specified above as part of the works, shall be carried out by the contractor on the same conditions in all respects including price on which he agreed to do the main works except as hereafter provided. The completion cost of any agreement for Maintenance works including works of upgradation, aesthetic, special repair, addition/ alteration shall not exceed 1.5 times of Tendered amount.</p>
<u>Deviations /Extra items, pricing</u>	<p>12.2 In the case of extra items (items that are completely new and are in addition to the items contained in the contract), the contractor may within 15 days of receipt of order or occurrence of the item(s) claim rate, supported by proper analysis, for the work and the Engineer-in-charge shall within one month of the receipt of the claims supported by analysis after giving considerations to the analysis of the rates submitted by the contractor, determined the rates on basis of market rates and the contractor shall be paid in accordance with the rates so determined.</p>	<p>12.2 A. For Project and original works: In the case of extra items (items that are completely new and are in addition to the items contained in the contract), the contractor may within 15 days of receipt of order or occurrence of the item(s) claim rate, supported by proper analysis, for the work and the Engineer-in-charge shall within one month of the receipt of the claims supported by analysis after giving considerations to the analysis of the rates submitted by the contractor, determined the rates on basis of market rates and the contractor shall be paid in accordance with the rates so determined. B. For Maintenance including works of upgradation, aesthetic, special repair, addition/ alteration: In the case of Extra Item(s) being the schedule items (Delhi Schedule of Rates items), these shall be paid as per the schedule rate plus cost index (at the time of tender) plus/minus percentage above</p>

		<p>below quoted contract amount.</p> <p>Payment of Extra items in case of non-schedule items (Non-DSR items) shall be made as per the prevailing market rate.</p>
<p><u>Deviations, Substituted items, pricing</u></p>	<p>In the case of substituted items (items that are taken up with partial substitution or lieu of items of work in the contract), the rate for the agreement item (to be substituted) and substituted item shall also be determined in the manner as mentioned in the following Para.</p> <p>(a) If The market rate for the substituted item so determined is more than the market rate of the agreement item (to be substituted), the rate payable to the contractor for the substituted item shall be the rate for the agreement item (to be substituted).</p> <p>(b) If the market rate for the substituted item so determined is less than the market rate of the agreement item (to be substituted), the rate payable to the contractor for the substituted item shall be the rate for the agreement item (to be substituted) so decreased to the extent of the difference between the market rates of substituted item and the agreement item (to be substituted)</p>	<p>A. For Project and original works: In the case of substituted items (items that are taken up with partial substitution or lieu of items of work in the contract), the rate for the agreement item (to be substituted) and substituted item shall also be determined in the manner as mentioned in the following Para.</p> <p>(a) If The market rate for the substituted item so determined is more than the market rate of the agreement item (to be substituted), the rate payable to the contractor for the substituted item shall be the rate for the agreement item (to be substituted).</p> <p>(b) If the market rate for the substituted item so determined is less than the market rate of the agreement item (to be substituted), the rate payable to the contractor for the substituted item shall be the rate for the agreement item (to be substituted) so decreased to the extent of the difference between the market rates of substituted item and the agreement item (to be substituted)</p> <p>B. For Maintenance including works of upgradation, aesthetic, special repair, addition/ alteration: In the case of Substitute Item(s) being the schedule items (Delhi Schedule of Rates items), these shall be paid as per the schedule rate plus cost index (at the time of tender) plus/minus percentage above below quoted contract amount. Payment of substituted items in case of non-schedule items (Non-DSR items) shall be made as per the prevailing market rate.</p>
<p><u>Deviations, Deviated Quantities, pricing</u></p>	<p>In the case of contract items, substituted items, contract cum substituted items, which exceed the limits laid down in schedule F, the contractor may within fifteen days of receipt of order or occurrence of the excess, claim revision of the rates, supported by proper analysis for the work in excess of the above mentioned limits, provided that if the rates so claimed are in excess of the rates specified in the schedule of quantities, the Engineer-in-Charge shall within one month of receipt of the claims supported by analysis, after giving consideration to the analysis of the rates submitted by the contractor, determine the rates on the basis of the market rates and the contractor shall be paid in accordance with the rates so determined.</p>	<p>A. For Project and original works: In the case of contract items, substituted items, contract cum substituted items, which exceed the limits laid down in schedule F, the contractor may within fifteen days of receipt of order or occurrence of the excess, claim revision of the rates, supported by proper analysis for the work in excess of the above mentioned limits, provided that if the rates so claimed are in excess of the rates specified in the schedule of quantities, the Engineer-in-Charge shall within one month of receipt of the claims supported by analysis, after giving consideration to the analysis of the rates submitted by the contractor, determine the rates on the basis of the market rates and the contractor shall be paid in accordance with the rates so determined.</p>

		<p>B. For Maintenance including works of upgradation, aesthetic, special repair, addition/ alteration:</p> <p>In the case of contract items, which exceed the limit laid down in schedule F, the contractor shall be paid rates specified in the schedule of quantities.</p>
	<p>12.3 The provisions of the preceding paragraph shall also apply to the decrease in the rates of items for the work excess of the limits laid down in Schedule F, and the Engineer-in-Charge shall after giving notice to the contractor within one month of occurrence of the excess and after taking into consideration any reply received from him within fifteen days of the receipt of the notice, revise the rates for the work in question within one month of the expiry of the said period of fifteen days having regard to the market rates.</p>	<p>12.3 A. For Project and original works:The provisions of the preceding paragraph shall also apply to the decrease in the rates of items for the work excess of the limits laid down in Schedule F, and the Engineer-in-Charge shall after giving notice to the contractor within one month of occurrence of the excess and after taking into consideration any reply received from him within fifteen days of the receipt of the notice, revise the rates for the work in question within one month of the expiry of the said period of fifteen days having regard to the market rates.</p> <p>B. For Maintenance including works of upgradation, aesthetic, special repair, addition/ alteration:</p> <p>In the case of decrease in the rates Prevailing in the market of items for the the work excess of the limits laid down in Schedule F, and the Engineer-in-Charge shall after giving notice to the contractor within one month of occurrence of the excess and after taking into consideration any reply received from him within fifteen days of the receipt of the notice, revise the rates for the work in question within one month of the expiry of the said period of fifteen days having regard to the market rates.</p>
	<p>14.The Tender of the work shall remain open for acceptance for a period of ninety (90) days from the date of opening of tenders / ninety days from the date of opening of financial bid in case Tenders are invited on 2/3 envelope system (strike out as case may be) if any Tenderer withdraws his tender before the said period or issue of letter of acceptance of acceptance, whichever is earlier or makes any modifications in the terms and conditions of the tender which are not acceptable to th department, then the Government shall, without prejudice to any other right or remedy, if the said earnest money as aforesaid, Further the tenderer shall not be allowed to participate in the retendering process of the work.</p>	<p><u>CPWD-6</u></p> <p>14.The Tender of the work shall remain open for acceptance for a period of ninety (90) days from the date of opening of tenders / Ninety days from the date of opening of Technical bid in case Tenders are invited on 2 envelope system / 120 days from the date of opening of Technical bids bids in case tenders are invited for specialized works on 3 envelope system (strike out as case may be) if any Tenderer withdraws his tender before the said period or issue of letter of acceptance of acceptance, whichever is earlier or makes any modifications in the terms and conditions of the tender which are not acceptable to the department, then the Government shall, without prejudice to any other right or remedy, if the said earnest money as aforesaid, Further the tenderer shall not be allowed to participate in the retendering process of the work.</p>
	<p>11. The contractor whose bid is accepted will be required to furnish performance guarantee of 5% (Five Percent) of the bid amount within the period specified in Schedule F. This guarantee shall be in the form of cash (in case guarantee amount is less than Rs. 10000/-) or Deposit at call receipt of any scheduled bank /Banker's cheque of any scheduled bank/ Demand Draft of any scheduled bank/ Pay Order of any Scheduled Bank of any Scheduled bank (in case guarantee amount is less than Rs. 1,00,000/-) or Government Securities or Fixed Deposit Receipts or Guarantee Bonds of any</p>	<p>11. The contractor whose bid is accepted will be required to furnish performance guarantee of 5% (Five Percent) of the bid amount within the period specified in Schedule F. This guarantee shall be in the form of cash (in case guarantee amount is less than Rs. 10000/-) or Deposit at call receipt of any scheduled bank /Banker's cheque of any scheduled bank/ Demand Draft of any scheduled bank/ Pay Order of any Scheduled Bank of any Scheduled bank (in case</p>

	<p>Scheduled Bank or the State Bank of India in accordance with the prescribed form. In case the contractor fails to deposit the said performance guarantee within the period as indicated in Schedule 'F', including the extended period if any, the Earnest Money deposited by the contractor shall be forfeited automatically without any notice to the contractor. The earnest money deposited along with bid shall be returned after receiving the aforesaid performance guarantee.</p>	<p>guarantee amount is less than Rs. 1,00,000/-) or Government Securities or Fixed Deposit Receipts or Guarantee Bonds of any Scheduled Bank or the State Bank of India in accordance with the prescribed form. In case the contractor fails to deposit the said performance guarantee within the period as indicated in Schedule 'F', including the extended period if any, the Earnest Money deposited by the contractor shall be forfeited automatically without any notice to the contractor. The earnest money deposited along with bid shall be returned after receiving the aforesaid performance guarantee.</p> <p>The Contractor whose bid is accepted will also be required to furnish either copy of applicable licenses/ registrations or proof of applying for obtaining labour licenses, registration with EPFO, ESIC and BOCW Welfare Board and Programme Chart (Time and Progress) Within the period specified in schedule in Schedule F.</p>
	No Provision	<p>No Running Account Bill shall be paid for the work till the applicable labour licenses, registration with EPFO, ESIC and BOCW Welfare Board, Whatever applicable are submitted by the contractor to the Engineer-in-Charge.</p>
	<p>The contractor shall obtain a valid license under the Contract Labour (R&A) Act, 1970 and the Contract Labour (Regulation and Abolition) Central Rules, 1971 before the commencement of the work, and continue to have a valid license until completion of the work.</p>	<p>The contractor shall obtain a valid license under the Contract Labour (R&A) Act, 1970 and the Contract Labour (Regulation and Abolition) Central Rules, 1971 before the commencement of the work, and continue to have a valid license until completion of the work.</p> <p>The contractor shall also comply with provisions of the Inter-State Migrant Workmen (Regulation of Employment and Conditions of Service) Act, 1979.</p>
	<p>(i)Time allowed for submission of performance Guarantee from the date of issue of letter of acceptance.....days.</p>	<p>(i)Time allowed for submission of performance Guarantee , Programme Chart (Time and Progress) and applicable labour licenses, registration with EPFO, 'ESIC and BOCW Wefare Board or proof of applying thereof from the date of issue of letter of acceptance.....days.</p>
	No Provision	<p>Whether Clause 7A Shall be Applicable Yes</p>
	<p>15. Sales-tax/VAT (except service tax), purchase tax, turnover tax any other tax applicable in respect of this contract shall be payable by the contractor and Government will not entertain any claim whatsoever in respect of service tax same shall be paid by the contractor to the concerned department on demand and it will be reimbursed to him by the engineer-in-charge after satisfying that it has been actually and genuinely paid by the contractor.</p>	<p>15. GST or any other tax applicable in respect of input procured by the contractor for this contract shall be payable by the Contractor and Government will not entertain any claim whatsoever in respect of the same, However, component of GST at time of supply of service (as provided in CGST Act 2017) provided by the contract shall be varied if different from that applicable on the last date of receipt of tender including, extension if any.</p>

	<p>CLAUSE 37</p> <p>(i) Sales Tax. Vat (except Service Tax), Building and other Construction Workers Cess or any other tax or Cess in respect of this contract shall be payable by the contractor and Government shall not entertain any claim whatsoever in this respect. However, in respect of service tax. same shall be paid the contractor to the concerned department on demand and it will be reimbursed to him by the Engineer-i-charge after satisfying that it has been actually and genuinely paid by the contractor.</p>	<p>CLAUSE- 37</p> <p>(i) GST, Building and other construction workers welfare Cess or any other tax, Levy or cess in respect of input for or output by this contract shall be payable by the contractor and Government shall not entertain any claim whatsoever in this respect except as provided under clause 38.</p>
	<p>CLAUSE-38</p> <p>(i) All tendered rates, shall be inclusive of all taxes and levies (except Service Tax) payable under respective statutes. However, if any further tax or levy or cess is imposed by the statute. after the last stipulated date for the receipt of tender including extensions if any and the contractor thereupon necessarily and properly pays such taxes/levies/cess, the contractor shall be reimbursed the amount so paid, provided such payments, if any, is not, in the opinion of the Superintending Engineer whose decision shall be final and binding on the contractor) attributable to delay in execution of work within the control of the contractor.</p>	<p>CLAUSE-38</p> <p>(i) All tendered rates shall be inclusive of any tax, levy or cess applicable on last stipulated date of receipt of tender including extension if any. No adjustment i.e, increase or decrease shall be made for any variation in the rate of GST, Building and Other Construction Workers Welfare Cess or any tax, levy or cess applicable on inputs. However, effect of variation in rates of GST or Building and Other Construction workers welfare Cess or imposition or repeal of any other tax, levy or cess applicable on output of the works contract shall be adjusted on either side, increase or decrease. Provided for Building and other Construction Workers Welfare Cess or any tax (other than GST), levy or cess varied or imposed after the last date of receipt of tender including extension if any, any increase shall be reimbursed to the contractor only if the contractor necessarily and properly pays such increased amount of taxes/levies/cess. Provided further that such adjustment including GST shall not be made in the extended period of contract for which the contractor alone in responsible for delay as determined by authority for extension of time under Clause 5 in Schedule F.</p>

BID SUBMISSION

ONLINE BID SUBMISSION

The Online bids (complete in all respect) must be uploaded online in **two** Envelops as explained below:-

Envelope – 1 (Following documents to be provided as single PDF file)			
Sl. No.	Documents	Content	File Types
1.	Technical Bid	Scanned copy /Online Payment of EMD	.PDF
2.		Enlistment order of contractor.	.PDF
3.		Attested certificate of work experience.	.PDF
4.		Certificate of Registration of GST and acknowledgment of up to date field return of GST.	.PDF
5.		Affidavit as per Notice Inviting Tender condition 1.3 of page 19 of NIT to be submitted on stamp paper.	.PDF
6.		Acceptance to execute INTEGRITY PACT.	.PDF
7.		Undertaking as per tender notice on firm's letter head if the scan copy of EMD uploaded.	.PDF
8.		ESI and EPF Registration.	PDF
9.		FORM "F" (Duly filled with all required details	.PDF
10.		Proof of tender fees	.PDF
11		Any other documents specified in NIT	PDF
Envelope – 2			
Sl. No.	TYPES	Content	
1.	Financial Bid	Price bid should be submitted in BOQ format.	.Xls

All above documents shall be as per Tender Notice.

SCHEDULE OF QUANTITY

Name of Work :- Renovation and modification of Seminar Hall in academic area at IIT Delhi

Sub Head: - Civil and Electrical & Furniture Work

Sr.No	Description	Qty	Unit	Rate	Amount
1	Providing and laying in position cement concrete of specified grade excluding the cost of centering and shuttering - All work up to plinth level :				
1.1	1:2:4 (1 Cement : 2 coarse sand (zone-III) : 4 graded stone aggregate 40 mm nominal size)	3.00	Cum.		
2	Centering and shuttering including strutting, propping etc. and removal of form for :				
2.1	Edges of slabs and breaks in floors and walls (For shuttering of steps water proof ply will be used and joint will be make water tight by filling POP or rubber gasket to get expose finish and nothing extra shall be payable on account of this)				
2.1.1	Under 20 cm wide	302.00	Mtr.		
3	Providing and laying in position machine batched and machine mixed design mix M-25 grade cement concrete for reinforced cement concrete work, using cement content as per approved design mix, including pumping of concrete to site of laying but excluding the cost of centering, shuttering, finishing and reinforcement, including admixtures in recommended proportions as per IS: 9103 to accelerate, retard setting of concrete, improve workability without impairing strength and durability as per direction of Engineer-in-charge. (Note :- Cement content considered in this item is @ 330 kg/cum. Excess/ less cement used as per design mix is payable/recoverable separately).				
3.1	All works upto plinth level (Top surface of RMC will be finished with cement sand mortal 1:2 (1 cement : 2 sand) with floating coat of neat cement when concrete is green and nothing extra shall be payable on account of this).	38.00	Cum.		
4	Brick work with common burnt clay F.P.S. (non modular) bricks of class designation 7.5 in foundation and plinth in:				
4.1	Cement mortar 1:4 (1 cement : 4 coarse sand)	9.00	Cum.		

5	Designing, fabricating, testing, installing and fixing in position Curtain Wall with Aluminium Composite Panel Cladding, with open grooves for linear as well as curvilinear portions of the building , for all heights and all levels etc. including:				
5.1	(a) Structural analysis & design and preparation of shop drawings for pressure equalisation or rain screen principle as required, proper drainage of water to make it watertight including checking of all the structural and functional design.				
5.1.1	(b) Providing, fabricating and supplying and fixing panels of aluminium composite panel cladding in pan shape in metallic colour of approved shades made out of 4mm thick aluminium composite panel material consisting of 3mm thick FR grade mineral core sandwiched between two Aluminium sheets (each 0.5mm thick). The aluminium composite panel cladding sheet shall be coil coated, with Kynar 500 based PVDF / Lumiflon based fluoropolymer resin coating of approved colour and shade on face # 1 and polymer (Service) coating on face # 2 as specified using stainless steel screws, nuts, bolts, washers, cleats, weather silicone sealant, backer rods etc.				
5.1.1.1	(c) The fastening brackets of Aluminium alloy 6005 T5 / MS with Hot Dip Galvanised with serrations and serrated washers to arrest the wind load movement, fasteners, SS 316 Pins and anchor bolts of approved make in SS 316, Nylon separators to prevent bi-metallic contacts all complete required to perform as per specification and drawing The item includes cost of all material & labour component, the cost of all mock ups at site, cost of all samples of the individual components for testing in an approved laboratory, field tests on the assembled working curtain wall with aluminium composite panel cladding, cleaning and protection of the curtain wall with aluminium composite panel cladding till the handing over of the building for occupation. Base frame work for ACP cladding is payable under the relevant aluminium item.s The Contractor shall provide curtain wall with aluminium composite panel cladding, having all the performance characteristics all complete , as per the Architectural drawings, as per item description, as specified, as per the approved shop drawings and as directed by the Engineer-in-Charge. However, for the purpose of payment, only the actual area on the external face of the curtain wall with Aluminum Composite Panel Cladding (including width of groove) shall be measured in sqm. up to two decimal places.	39.00	Sqm.		
6	Extra for providing vision panel not exceeding 0.1 sqm in all type of flush doors (cost of glass excluded) (overall area of door shutter to be measured):				

6.1	Rectangular or square	10.00	Sqm.		
7	Providing and fixing aluminium sliding door bolts, ISI marked anodised (anodic coating not less than grade AC 10 as per IS : 1868), transparent or dyed to required colour or shade, with nuts and screws etc. complete :				
7.1	250x16 mm	8.00	Each.		
8	Providing and fixing aluminium tower bolts, ISI marked, anodised (anodic coating not less than grade AC 10 as per IS : 1868) transparent or dyed to required colour or shade, with necessary screws etc. complete :				
8.1	250x10 mm	9.00	Each		
9	Providing and fixing aluminium handles, ISI marked, anodised (anodic coating not less than grade AC 10 as per IS : 1868) transparent or dyed to required colour or shade, with necessary screws etc. complete :				
9.1	125 mm	22.00	Each		
10	Providing and fixing bright finished brass 100 mm mortice latch and lock, ISI marked, with six levers and a pair of anodised (anodic coating not less than grade AC 10 as per IS : 1868) aluminium lever handles of approved quality with necessary screws etc. complete.	8.00	Each.		
11	Providing and fixing thermal insulation with Resin Bonded rock wool conforming to IS: 8183, having density 48 kg/m ³ , 50 mm thick, wrapped in 200 G Virgin Polythene Bags fixed to wall with screw, rawel plug & washers and held in position by criss crossing GI wire etc. complete as per directions of Engineer-inCharge.	888.00	Sqm.		
12	12 mm cement plaster of mix				
12.1	1:4 (1 cement: 4 fine sand)	40.00	Sqm.		
13	15 mm cement plaster on the rough side of single or half brick wall of mix :				
13.1	1:4 (1 cement: 4 fine sand)	35.00	Sqm.		
14	Wall painting with acrylic emulsion paint of approved brand and manufacture to give an even shade :				
14.1	Two or more coats on new work	587.00	Sqm.		
15	Painting with synthetic enamel paint of approved brand and manufacture of required colour to give an even shade :				
15.1	Two or more coats on new work over an under coat of suitable shade with ordinary paint of approved brand and manufacture	37.00	Sqm.		
16	Providing and applying white cement based putty of average thickness 1 mm, of approved brand and manufacturer, over the plastered wall surface to prepare the surface even and smooth complete	587.00	Sqm		

17	Repairs to plaster of thickness 12 mm to 20 mm in patches of area 2.5 sq.meters and under, including cutting the patch in proper shape, raking out joints and preparing and plastering the surface of the walls complete, including disposal of rubbish to the dumping ground, all complete as per direction of Engineer-in-Charge				
17.1	With cement mortar 1:4 (1 cement : 4 fine sand)	40.00	Sqm.		
18	Removing dry or oil bound distemper, water proofing cement paint and the like by scrapping, sand papering and preparing the surface smooth including necessary repairs to scratches etc. complete.	708.00	Sqm.		
19	Melamine polishing on wood work (one or more coat).	132.00	Sqm.		
20	Demolishing cement concrete manually/ by mechanical means including disposal of material within 50 metres lead as per direction of Engineer - in - charge.				
20.1	Nominal concrete 1:4:8 or leaner mix (i/c equivalent design mix)	59.00	Cum.		
21	Demolishing R.C.C. work manually/ by mechanical means including stacking of steel bars and disposal of unserviceable material within 50 metres lead as per direction of Engineer - in- charge	6.00	Cum.		
22	Demolishing brick work manually/ by mechanical means including stacking of serviceable material and disposal of unserviceable material within 50 metres lead as per direction of Engineer-in-charge				
22.1	In cement mortar	3.00	Cum.		
23	Dismantling doors, windows and clerestory windows (steel or wood) shutter including chowkhats, architrave, holdfasts etc. complete and stacking within 50 metres lead :				
23.1	Of area 3 sq. metres and below	29.00	Each		
24	Dismantling wood work in frames, trusses, purlins and rafters up to 10 metres span and 5 metres height including stacking the material within 50 metres lead :				
24.1	Of sectional area 40 square centimetres and above	26.00	Cum.		
25	Dismantling wooden boardings in lining of walls and partitions, excluding supporting members but including stacking within 50 metres lead :				
25.1	Thickness above 10 mm up to 25 mm	116.00	Sqm.		

26	Dismantling cement asbestos or other hard board ceiling or partition walls including stacking of serviceable materials and disposal of unserviceable materials within 50 metres lead.	165.00	Sqm.		
27	Disposal of building rubbish / malba / similar unserviceable, dismantled or waste materials by mechanical means, including loading, transporting, unloading to approved municipal dumping ground or as approved by Engineer-in-charge, beyond 50 m initial lead, for all leads including all lifts involved.	106.00	Cum.		
28	Providing and fixing aluminium work for doors, windows, ventilators and partitions with extruded built up standard tubular sections/ appropriate Z sections and other sections of approved make conforming to IS: 733 and IS: 1285, fixing with dash fasteners of required dia and size, including necessary filling up the gaps at junctions, i.e. at top, bottom and sides with required EPDM rubber/ neoprene gasket etc. Aluminium sections shall be smooth, rust free, straight, mitred and jointed mechanically wherever required including cleat angle, Aluminium snap beading for glazing / paneling, C.P. brass / stainless steel screws, all complete as per architectural drawings and the directions of Engineer-in-charge. (Glazing, paneling and dash fasteners to be paid for separately) :				
28.1	For fixed portion				
28.1.1	Powder coated aluminium (minimum thickness of powder coating 50 micron)	810.00	Kg.		
29	For shutters of doors, windows & ventilators including providing and fixing hinges/ pivots and making provision for fixing of fittings wherever required including the cost of EPDM rubber / neoprene gasket required (Fittings shall be paid for separately)				
29.1	Powder coated aluminium (minimum thickness of powder coating 50 micron)	105.00	Kg.		
30	Providing and fixing glazing in aluminium door, window, ventilator shutters and partitions etc. with EPDM rubber / neoprene gasket etc. complete as per the architectural drawings and the directions of engineer-in-charge . (Cost of aluminium snap beading shall be paid in basic item):				
30.1	With float glass panes of 5 mm thickness (weight not less than 12.50 kg/ sqm)	93.00	Sqm.		
31	Providing and fixing double action hydraulic floor spring of approved brand and manufacture conforming to IS : 6315, having brand logo embossed on the body / plate with double spring mechanism and door weight upto 125 kg, for doors, including cost of cutting floors, embedding in floors as				

	required and making good the same matching to the existing floor finishing and cover plates with brass pivot and single piece M.S. sheet outer box with slide plate etc. complete as per the direction of Engineer-in-charge.				
31.1	With stainless steel cover plate minimum 1.25 mm thickness	4.00	Each		
32	Providing and fixing Brass 100mm mortice latch and lock with 6 levers without pair of handles (best make of approved quality) for aluminium doors including necessary cutting and making good etc. complete.	2.00	Each		
33	<p>Supplying and placing in position auditorium chair of Godrej Make Model MARS WITH DESKLET with following specifications. The armrest- is made up of integral skin polyurethane foam with 65+/- 10 shore A hardness and reinforced with wooded insert. The armrest is fitted with sidepanel through an concealed zinc plated hinge.</p> <p>Foam- Foam is HR Polyurethane foam with density = 45+/-kg/m³. Seat Assembly- The seat assembly is made of polyurethane foam moulded with M.S. tubular frame insert which is upholstered with fabric. The insert is tubular made of 1.9 +/-0.02cmX 0.16 +/- 0.013cm thk MS ERW round tube with flexible support straps running across the length and width of the frame. The seat has an auto – tipup feature making it stay in upright position when not in use enabling clear row passage (Approx. seat size: 45.5 cm (W) X 46.5 cm(D)).</p> <p>Backrest Assembly: The back assembly has a flexi back mechanism. It is made of polyurethane foam moulded with M.S tubular frame insert upholstered with fabric and has a plastic back cover. The insert is a tubular frame made of 1.9+/- 0.02 cm X 0.16+/- 0.013 cm thk M.S ERW round tube with flexible support straps running across the length & width of the frame. Back size- 45.5cm (W) X 70.4cm (H).</p> <p>Retractable Desklet- The desklet is made of 1.8+/- 0.05 thkprelaminated particleboard with-in-situ injection moulded polypropylene edge all around. Desklet top is mounted on high pressure die-cast aluminum arm through metal bracket 0.2+/- 0.05cm thk H.R Steel. The assembly is mounted on side panel through desklet arm connector made up of glass filled nylon. Desklet dimension 27+/- 0.1 cm (W)X 32.0+/-0.1cm (D) Power Coating- Steel Components are epoxy polyester coated (DFT 40 to 60 microns)</p> <p>Note- In this estimates, Godrej interio’s ‘ MARS model with Desklet’ for auditorium chair has been considered. In case of other makes, technical specifications should be equivalent and cost adjustment shall also be done if the equivalent make is of lesser market price than Godrej intero Mars with desklet.</p>	342.00	Nos.		
34	Providing wall panelling of approved make as per specification and direction of EIC at all heights and levels.				

34.1	<p>Providing and Fixing Channeled Woodworks perforated panels of Armstrong Industries / Saint Gobain or approved equivalent make of width 192mm, thickness 15mm and length 2400mm or as required by the Engineer-in-Charge, made of a medium density particle board substrate with a laminated facing as per the approved shade/species & finish and a melamine balancing layer on the reverse side. The boards shall have a special perforation pattern where the visible surface has a ("Helmholtz" fluted perforation of 3mm width and 21mm visible panel) each. The panels shall provide a minimum sag resistance of RH90 and a fire rating class of 1 as per Part 7 of BS 476. The edges of the panels shall be "tongue-and-grooved" to receive special clips for installation. The back of the perforated panel shall have sound absorbing non-woven acoustical fleece with NRC > 0.5. The panels shall be mounted on special aluminium splines using clips as approved by the Engineer-in-Charge</p>				
34.1.1	<p>Install wooden battens (provided by others) of section 50x50mm or as approved by the Architect on the solid wall horizontally using screws and plugs at spacing of 600mm centre-to-centre. Screw the aluminium extruded keel for channelled woodworks provided by Armstrong over the lowest and second wooden batten at an on-centre distance of 600mm. Install the Skirting (provided by others) of width 50mm or more as required by the Architect/ Engineer-in-Charge and insert the tongue end of the panel in the skirting. Place the inside clip on the groove end of the panel along the Al keel and then place the tongue end of the next panel. Continue installing rows of panels by inserting the tongue into the groove of the earlier inserted panel and progressively installing inside clips into the next keel till the actual height is achieved. Finish off the edges using wooden moulding of matching colour (provided by others). Installation to be carried out by Armstrong Trained Installation team & Installation should be carried out as per manufacturer recommended procedure. (Make-Armstrong, Anutone, Credence, Topakustic)</p>	888.00	Sqm.		
35	<p>Providing and fixing 2 mm thick homogeneous polyvinile chlorifde sheet / tile in flooring and skirting in approved pattern on a smooth and damp proof base using rubber based adhesive of (approved quality and manufacturer like fevicol Sr 998 or equivalent including rolling with light wooden roller weighing about 5 kg. all complete as directed by Engineer-in-charge. approved colour and shade. (Armstrong / Polyflor./ Tarkett</p>	840.00	Sqm.		

36	Providing and applying acrylic aggregate textured wall coating in pigmented finish (Spectra Plast 1053 - of soectrum paints / Rustic texture paints of Dulex / Rustic texture paints of Burger) maintaining material consumption rate of average 3.0 to 3.5 Kg. per Sqm. and upto 2 mm. average thickness on new walls in the exterior / interiors of the building. Undulations, broken edges, minor imperfections / irregularities should be rectified by using a paste made of Spectrum Rectochem Surface Improver mixed with ordinary portland cement in the ratio of 1:1. Old, flaking, plaster of paris, gypsum and highly absorbent surfaces and those already finished with lime or distemper should be brushed down and then treated with a coat of Spectrum Prime Coat or equivalent diluted with water as per the rcomandation of manufacturer applied by a brush.	122.00	Sqm.		
37	Providing and fixing 12 mm frame less toughened glass of approved brand and manufacturer in railings fixed to RCC member with the help of 4 mm thick, 265 mm high M.S. chanel and other fittings and fixtures as per architectural drawing and instruction of Engineer in Charge all complete. (Rate shall be inclusive M.S. chanel and all other fittings/fixtures).	23.00	Sqm.		
38	Providing and fixing factory made hot pressed both side laminated flush door ready made shutter with one mm thick decorative laminate on both side confirming to IS:2202 (Part-I) non decorative type, core of block board construction with frame of 1st class hard wood and well matched teak 3 ply veneering with vertical grain or cross bands and face veneer on both face of shutters.				
38.1	35mm thick including ISI marked stainless steel butt hinges with necessary screws.	16.00	Sqm.		
39	Dismantling old damaged PVC flooring work including stacking material within 50 metres lead. For any thickness.	605.00	Sqm.		
ELECTRICAL WORK					
40	Wiring for light point/ fan point/ exhaust fan point/ call bell point with 1.5 sq.mm FR PVC insulated copper conductor single core cable in surface / recessed steel conduit, with modular switch, modular plate, suitable GI box and earthing the point with 1.5 sq.mm. FR PVC insulated copper conductor single core cable etc as required.				
40.1	Group C	100	Point		
1	Wiring for light/ power plug with 2X4 sq. mm FR PVC insulated copper conductor	200	Mtr.		

	40.3single core cable in surface/ recessed steel conduit alongwith 1 No 4 sq. mm FR PVC insulated copper conductor single core cable for loop earthing as required.				
42	Wiring for circuit/ submain wiring alongwith earth wire with the following sizes of FR PVC insulated copper conductor, single core cable in surface/ recessed steel conduit as required				
42.1	2 X 1.5 sq. mm + 1 X 1.5 sq. mm earth wire	100	Mtr.		
42.2	2 X 2.5 sq. mm + 1 X 2.5 sq. mm earth wire	200	Mtr.		
42.3	2 X 4 sq. mm + 1 X 4 sq. mm earth wire	150	Mtr.		
42.4	2 X 6 sq. mm + 1 X 6 sq. mm earth wire	125	Mtr.		
43	Supplying and fixing following modular switch/ socket on the existing modular plate & switch box including connections but excluding modular plate etc. as required.				
43.1	15/16 amp switch	100	Each		
43.2	6 pin 15/16 amp socket outlet	100	Each		
44	Supplying and fixing following size/ modules, GI/PVC box alongwith modular base & cover plate for modular switches in recess etc as required.				
44.1	3 Module (100mmX75mm)	10	Each		
44.2	6 Module (200mmX75mm)	15	Each		
44.3	12 Module (200mmX150mm)	15	Each		
45	Supplying and installation of Surface mounting LED luminaire equipped with CRCA powder coating housing, anti glare polycarbonate diffuser with energy efficient electronic driver with following features:- Suitable for operating voltage and frequency: 130-300 Va.c, 50 Hz.; wattage 34 Watts;Output lumens not less than 3300 lm; CCT 4000K; Dimension in mm (600X600); Nominal surge protection 2.5 kV;Power factor not less than 0.9; Minimum IP protection 20;	20	Each		
46	Supplying and installation of Surface mounting round LED luminaire equipped with extruded aluminium housing with opal PMMA with energy efficient electronic driver with following features:- Suitable for operating voltage and frequency: 130-300 Va.c, 50 Hz.; wattage 21 Watts; CCT 4000K; Dimension in mm (234); Nominal surge protection 2.5 kV;Power factor not less than 0.9; Minimum IP protection 20;	20	Each		
47	Supplying and installation of Recess mounting round LED luminaire equipped with fully enclosed precision die-cast aluminium construction,excellent pan with energy efficient electronic driver with	30	Each		

	following features:-Suitable for operating voltage and frequency: 130-300 Va.c, 50 Hz.; wattage 45 Watts; CCT 4000K; Dimension 215 mm cutout ; Nominal surge protection 2.5 kV;Power factor not less than 0.9; Minimum IP protection 20;				
48	Supplying and installation of Recess mounting round LED luminaire equipped with fully enclosed precision die-cast aluminium construction,excellent pan with energy efficient electronic driver with following features:-Suitable for operating voltage and frequency: 130-300 Va.c, 50 Hz.; wattage 15 Watts; CCT 4000K; Dimension 155 mm cutout ; Nominal surge protection 2.5 kV;Power factor not less than 0.9; Minimum IP protection 20;	70	Each		
49	Supplying and fixing of 5 star rated, 1200mm sweep Ceiling fan complete with all accessories for use on 220/240 volts 50 HZ, single phase A/C Supply including wiring the down rod of standard length upto 30cm with 1.5 sq. mm FRLS PVC insulated, copper conductor single/ multi core cable etc as reqd.	8	Each		
50	Supplying and fixing two module stepped type electronic fan regulator on the existing modular plate switch box including connections but excluding modular plate etc. as required.	8	Each		
51	Providing and fixing M.S fan hook for ceiling fan including digging in RCC & making good the same complete as required.	8	Each		
52	Supplying and fixing modular blanking plate on the existing modular plate & switch box excluding modular plate as required.	20	Each		
53	Supplying and fixing following way, single pole and neutral, sheet steel, MCB distribution board, 240 volts, on surface/ recess, complete with tinned copper bus bar, neutral bus bar, earth bar, din bar, interconnections, powder painted including earthing etc. as required. (But without MCB/RCCB/Isolator)				
53.1	8 way, Double door	1	Each		
53.2	12 way, Double door	2	Each		
54	Supplying and fixing of following ways surface/ recess mounting, vertical type, 415 volts, TPN MCB distribution board of sheet steel, dust protected, duly powder painted, inclusive of 200 amps tinned copper bus bar, common neutral link, earth bar, din bar for mounting MCB's (but without MCB's and incomer) as required . (Note : Vertical type MCB TPDB is normally used where 3 phase outlets are required.)				
54.1	8 way (4 + 24), Double door	1	Each		

54.2	12 way (4 + 36), Double door	2	Each		
55	Supplying and fixing 5 amps to 32 amps rating, 240/415 volts, "C" curve, miniature circuit breaker suitable for inductive load of following poles in the existing MCB DB complete with connections, testing and commissioning etc. as required.				
55.1	Single pole	110	Each		
55.2	Single pole and neutral	3	Each		
55.3	Triple pole	6	Each		
56	Supplying and fixing 125 amps, 18 KA, TP MCCB in the existing TPN Distribution board/ panel board including testing & commissioning etc. complete as required.	3	Each		
57	Supplying and fixing 100 amps, 18 KA, TP MCCB with Steel Enclosure including testing & commissioning etc. complete as required.	3	Each		
58	Supplying and fixing following rating, double pole, 240 volts, MCB in the existing MCB DB complete with connections, testing and commissioning etc. as required.				
58.1	63 amps	3	Each		
59	Supplying and fixing Cable End Box (Loose Wire Box) suitable for following single pole and neutral, sheet steel, MCB distribution board, 240 Volts, on surface/ recess, complete with testing and commissioning etc. as required. For 8/12 way, Double door SPN MCBDB	3	Each		
60	Supplying and fixing Cable End Box (Loose Wire Box) suitable for following triple pole and neutral, sheet steel, MCB distribution board, 415 Volts, on surface/ recess, complete with testing and commissioning etc. as required. For 8/ 12 way, Double door TPN MCBDB	3	Each		
61	Supplying and fixing of 250mm sweep Fresh Air fan complete with suitable size louvers and PVC housing with all accessories suitable for use on 230 V , 50 Hz supply in the existing opening, including making good the damage , connection, testing and commissioning etc. as required.	2	Each		
62	Supplying and fixing of 300 mm size exhaust fan complete with suitable size louvers with all accessories suitable for use on 230 V , 50 Hz supply in the existing opening, including making good the damage , connection, testing and commissioning etc. as required.as required	2	Each		
63	Supplying and making end termination with brass compression gland and aluminium lugs for following size of PVC insulated and PVC				

	sheathed / XLPE aluminium conductor cable of 1.1 KV grade as required.				
63.1	4 X 25 sq. mm (28mm)	6	Each		
63.2	4 X 50 sq. mm (35mm)	6	Each		
63.3	3½ X 120 sq. mm (45mm)	3	Each		
64	Supplying and Laying of PVC insulated, PVC sheathed XLPE aluminium conductor armored cable of Following size, 1.1 KV grade conforming to I.S-1554/1/88				
64.1	4 X 25 sq. mm	100	Meter		
64.2	4 X 50 sq. mm	80	Meter		
64.3	3½ X 120 sq. mm	50	Meter		
65	Providing and fixing 8 SWG dia G.I. wire on surface or in recess for loop earthing along with existing surface/ recessed conduit/ submain wiring/ cable as required.	460	Meter		
66	Installation, testing and commissioning of pre-wired, fluorescent fitting / compact fluorescent fitting of all types, complete with all accessories and tube etc. directly on ceiling/ wall, including connection with 1.5 sq. mm FR PVC insulated, copper conductor, single core cable and earthing etc. as required.	10	Each		
67	Installation, testing and commissioning of ceiling fan, including wiring the down rods of standard length (upto 30 cm) with 1.5 sq. mm FR PVC insulated, copper conductor, single core cable, including providing and fixing phenolic laminated sheet cover on the fan box etc. as required.	5	Each		
68	Installation of exhaust fan in the existing opening, including making good the damage, connection, testing, commissioning etc. as required.				
68.1	Upto 450 mm sweep	2	Each		
69	Fabrication, supply, installation testing & commissioning of indoor type compartmentalized panel board made out of 2mm thick CRCA sheet having separate cable and bus bar alley double door arrangement with two leaf door on front side and single door with double leaf on rear side with locking arrangement, having 400 amp TPN Aluminium bus bar with base frame made out of 50x50x6mm thick angle iron having 300 mm legs duly erection in ground with connection and interconnection with copper conductor PVC insulated cables/ insulated copper conductor strip of appropriate size and terminals blocks (on outgoing) including supplying and fixing following switch gears & accessories there in	1	Nos.		

	<p>powder coating labelling earthing etc. complete as required</p> <p>1. Having minimum size = 800mm x 1400mm x 300mm deep.</p> <p>(a) 250 amps, 4P, 36KA, 50HZ, 415V, AC MCCB L&T , legrand, Schnieder Make= 1 No</p> <p>(b) 100 Amps 3 Pole, 18KA 415V, 50HZ MCCB L&T,legrand, Schnieder Make=4 Nos</p> <p>(c) Earthing studs 2 Nos</p> <p>(d) Danger plate – 02 Nos</p> <p>(e) Multimeter - 01 Nos.</p> <p>(e) RYB indicating lamp</p>				
70	<p>Fabrication, supply, installation testing & commissioning of indoor low rise Lift platform suitable for domestic and public access with free standing facility & appropriate size including supplying and fixing following specification etc. complete as required. Model</p> <p>Type:- Low Rise Lifting Platform</p> <p>Rated Load:- 300 kg</p> <p>Rated Speed:- 20 mm/s</p> <p>Drive Type:- Electro-hydraulic</p> <p>Power Supply:- 230V, single phase, 50hz</p> <p>RCD protected fused spur</p> <p>Travel:- Up to 1000mm without a pit recess, or 935mm with pit recess</p> <p>Footprint:- 1890mm x 1304mm</p> <p>Platform Size:- 1450mm x 800mm</p> <p>Location:- Internal or external</p> <p>Upper Gate:- Manual, self closing 900mm wide with steel infill</p> <p>Controls:- Standard landing call buttons,Landing controls post mounted at both levels, Car control rocker switch with emergency stop, Hold to run operation.</p> <p>Safety Features:- Platform and ramp safety sensitive devises, Manual emergency lowering.</p> <p>Weight:- 200 kg unladen</p> <p>Loadings:- Lift Base 5kn, gate if fitted 1kn per fixing</p> <p>Documentation:- Owners guide issued on completion.</p>	1	Nos.		
Credit for Dismantled Unserviceable Material					
71	Fire wood etc.	100.00	Kg		
72	Old flush door shutter of various thickness and sizes with fitting etc.	7.00	Each		
73	Old M.S section / steel bars scrap / G.I pipes / C.I pipes etc.	20.00	Kg.		
74	Old scrap aluminium sections of various size and thickness.	30.00	Kg.		
75	Old cement asbestos or other hard board ceiling	165.00	Sqm.		
76	Old chair with bracket	490.00	Nos.		

77	Less buyback of T5/ tube light/ conventional light etc. on as is where is basis.	35.00	Nos.		
78	Less buyback of 48 " Ceiling fan etc. on as is where is basis.	8.00	Nos.		
79	Less buyback of 10 " Fresh air/Exhaust fan etc. on as is where is basis.	2.00	Nos.		
80	Less buyback of MS conduit/ iron/ Steel items etc. on as is where is basis.	1.00	Lot.		
81	Less buyback of old aluminium wiring on as is where is basis.	1.00	Lot.		
TOTAL					

Special Conditions:

1. No labour huts shall be allowed in IIT Campus and nothing shall be paid extra on this account.
2. The contractor must visit the site of work /buildings before quoting the rates.
3. No labour to stay in IIT Campus nothing shall be paid extra on this account.
4. Site shall be available in parts or phases as per directions of Engineer in Charge and nothing extra on this account shall be paid to the Contractor.
5. Quoted rates of participating agencies shall be inclusive of GST.